

TECHNICAL DOCUMENTATION

WOLF COMFORT SLIMLINE VENTILATION UNIT

CFL-WRG / CFL-EC

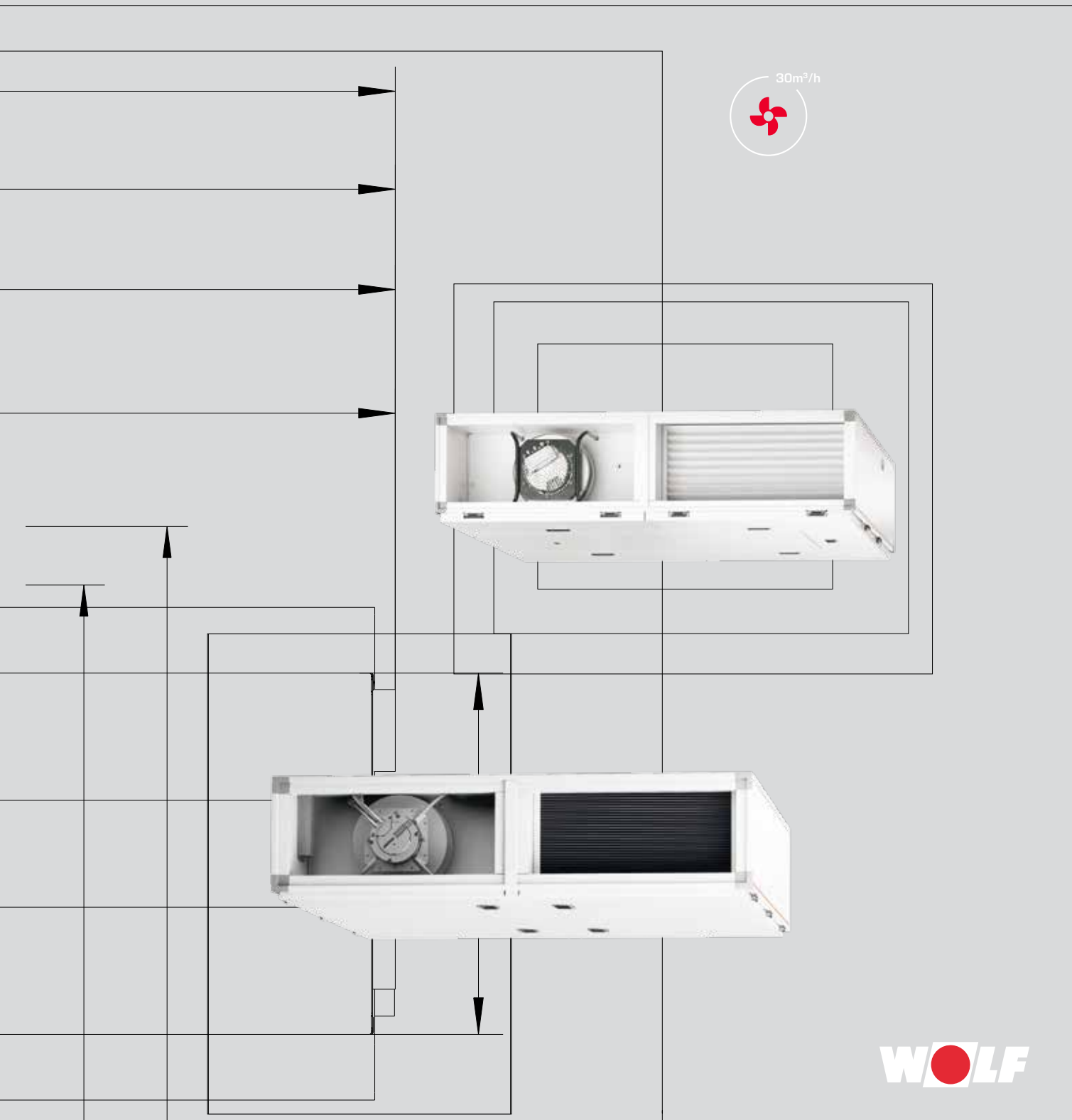

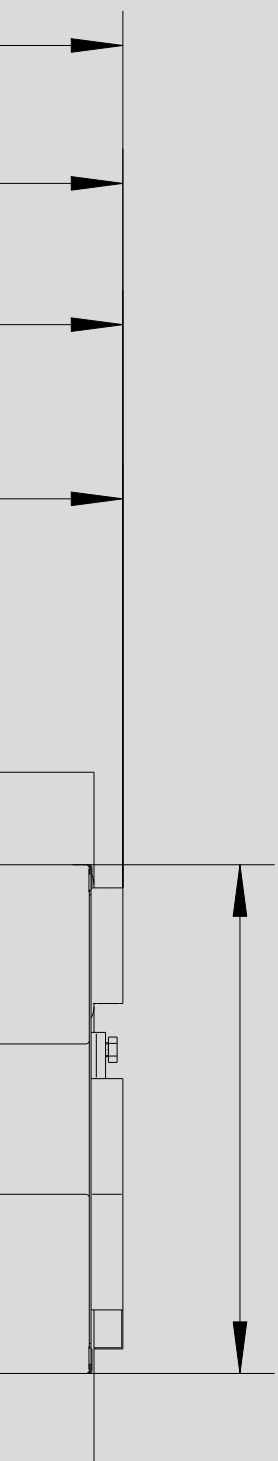

THE EXTENSIVE EQUIPMENT RANGE

from system supplier WOLF offers the ideal solution for commercial and industrial buildings, new build and modernisation projects alike. The range of WOLF control units can meet any requirement for heating convenience. All equipment is easy to operate, highly energy efficient and reliable. Solar thermal systems can be swiftly integrated into existing systems.

WOLF equipment is easy and quick to install and maintain.

COMFORT SLIMLINE VENTILATION UNIT WITH HEAT RECOVERY	CFL-WRG	04-05
UNIT DESCRIPTION		06
TYPES / DIMENSIONS		07-08
SPECIFICATION		09
COMPONENT DESCRIPTION		10
WRS-K CONTROL UNIT		11
OUTPUT DIAGRAMS		12-15
COMFORT SLIMLINE VENTILATION UNIT	CFL-EC	16
UNIT DESCRIPTION		17
TYPES / DIMENSIONS		18
SPECIFICATION		19
COMPONENT DESCRIPTION		20
OUTPUT DIAGRAMS		21-26
ACCESSORIES		27-38
CONTROL ACCESSORIES		<?>-37
TECHNICAL INFORMATION		39-43

COMFORT SLIMLINE VENTILATION UNIT CFL-WRG

High performance countercurrent plate heat exchanger made from corrosion-resistant aluminium alloy

Combined **supply and extract air unit as a slimline design**, for ceiling installation and control from below

Fans designed with **free-running impellers**, variable speed control with EC technology

Compact unit dimensions up to 3200 m³/h

Compliant with **Hygiene Guideline VDI 6022**

Unit is **fully wired** for fast, straightforward commissioning



10 BENEFITS OF THE WOLF COMFORT SLIMLINE VENTILATION UNIT CFL-WRG

A wide range of accessories is available

Programming unit **BMK** can also be used as a **remote control**

Control cabinet with WRS-K control unit installed on the side of the ventilation unit [CFL 10/15/22] or integrated in the unit [CFL 32]; choice of control unit for PWW or electric reheating coil

Isolator can be optionally **integrated** in the control cabinet [CFL 10/15/22]

COMFORT SLIMLINE VENTILATION UNIT CFL-WRG
COMBINED SUPPLY AND EXTRACT AIR UNITS WITH HEAT RECOVERY
 BASIC VERSION PWW (FOR CONTROLLING A PWW REHEATING COIL), OPTIONALLY
 ALSO AVAILABLE IN VERSION E (FOR CONTROLLING AN ELECTRIC REHEATING COIL)

Application range

Wolf CFL Comfort slimline ventilation units are designed as ceiling mounted internal units for controlled ventilation in modern properties. Their compact installed height makes them ideal for use in suspended ceilings. The components used and the structure of the unit meet the ever more stringent requirements concerning energy efficiency and hygiene.

CFL slimline units with heat recovery supply rooms with filtered outdoor air in sufficient, infinitely variable amounts. At the same time, a corresponding volume of stale indoor air containing CO₂ is removed and expelled as exhaust air. This results in other pollutants such as odours, fine dust, moisture etc. being removed effectively as well.

Due to the structure of the unit and the components used, the WOLF CFL-WRG Comfort slimline ventilation unit with heat recovery meets the requirements of regulations regarding energy savings and air hygiene in buildings, which are becoming increasingly significant.

Heat is recovered by means of an aluminium countercurrent plate heat exchanger (PWT) with efficiency levels up to and exceeding 90 %. If used in combination with the latest EC motor technology, this can result in a significant reduction in primary energy costs.

Top view

Connection side on the left in the supply air direction

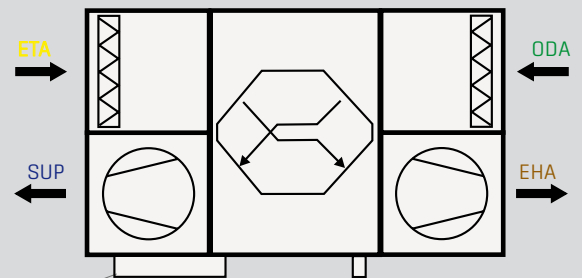

only on CFL-10/15/22

Connection side on the right in the supply air direction

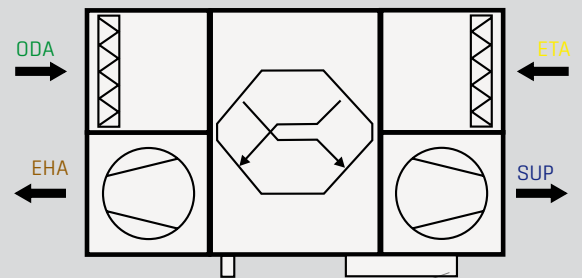

only on CFL-10/15/22

SIZE	TYPE	MAX. AIR VOLUME
CFL-10	WRG-PWW	1000 m ³ /h
	WRG-E	
CFL-15	WRG-PWW	1500 m ³ /h
	WRG-E	
CFL-22	WRG-PWW	2200 m ³ /h
	WRG-E	
CFL-32	WRG-PWW	3200 m ³ /h
	WRG-E	

COMFORT SLIMLINE VENTILATION UNIT CFL-WRG
UNIT DESCRIPTION

EXAMPLE UNIT CFL-WRG-10/15/22 INTERNAL UNIT FOR CEILING INSTALLATION

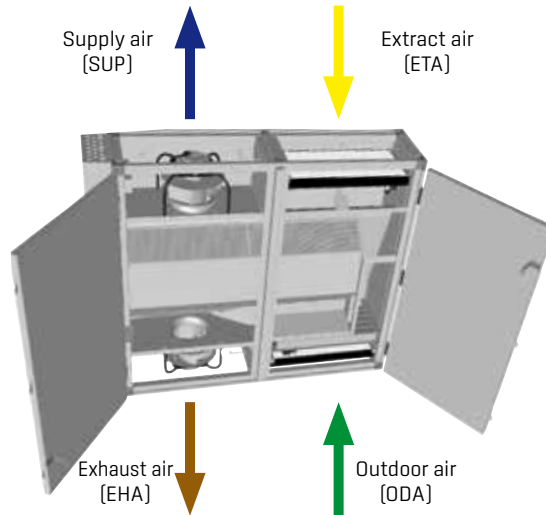

EXAMPLE UNIT CFL-WRG-32 INTERNAL UNIT FOR CEILING INSTALLATION

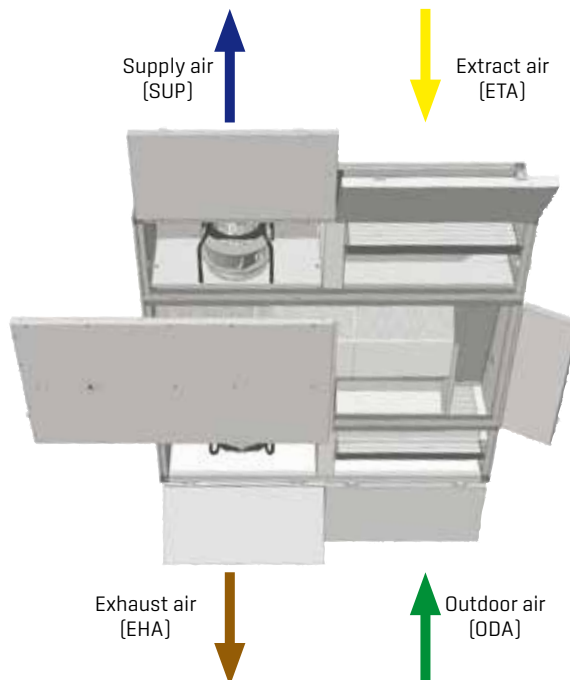

CFL-WRG COMFORT SLIMLINE VENTILATION UNIT (CFL 10 / 15 / 22)

Operating side supply air on the right / supply air on the left = mirror image

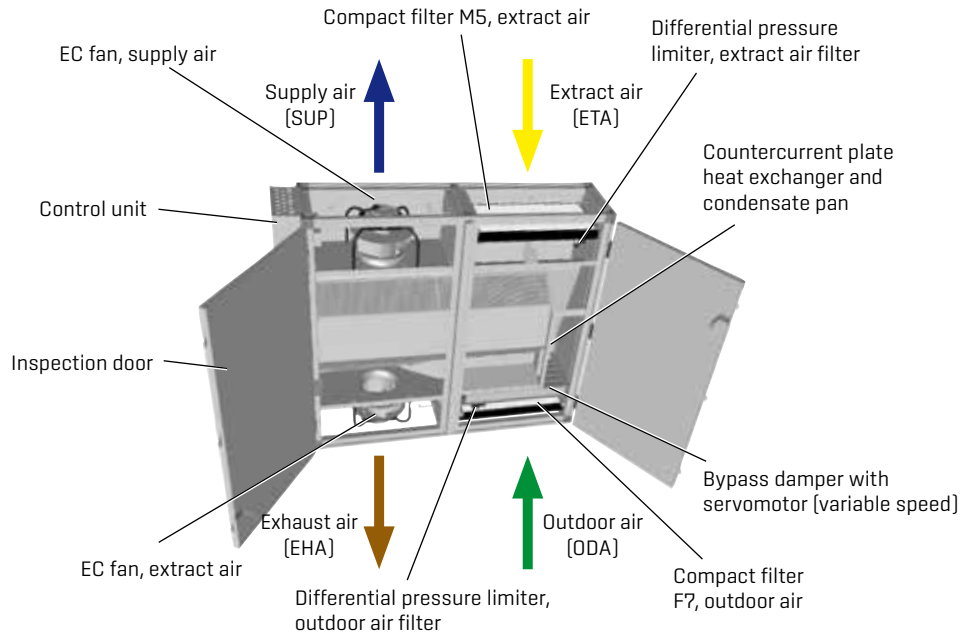

DIMENSIONS

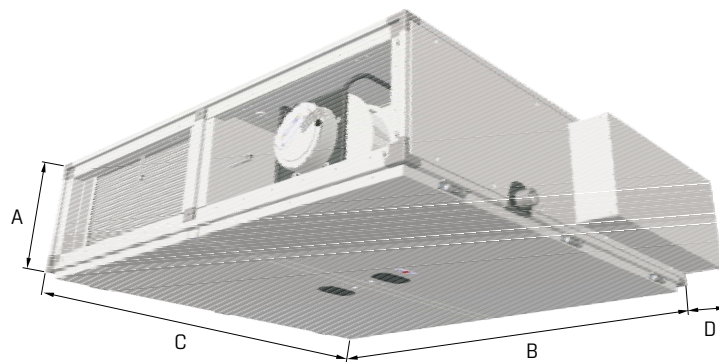

TYPE		CFL10-WRG	CFL15-WRG	CFL22-WRG
Height	A mm	367	367	411
Width	B mm	1017	1423	1830
Length	C mm	1322	1322	1525
Control cabinet width	D mm	115	115	115

The diagram shows the unit with the connection side on the right in the supply air direction
 (Connection side on the left in the supply air direction would be the mirror image)

COMFORT SLIMLINE VENTILATION UNIT CFL-WRG

TYPES / DIMENSIONS

CFL-WRG SLIMLINE VENTILATION UNIT (CFL 32)

Operating side supply air on the right / supply air on the left = mirror image

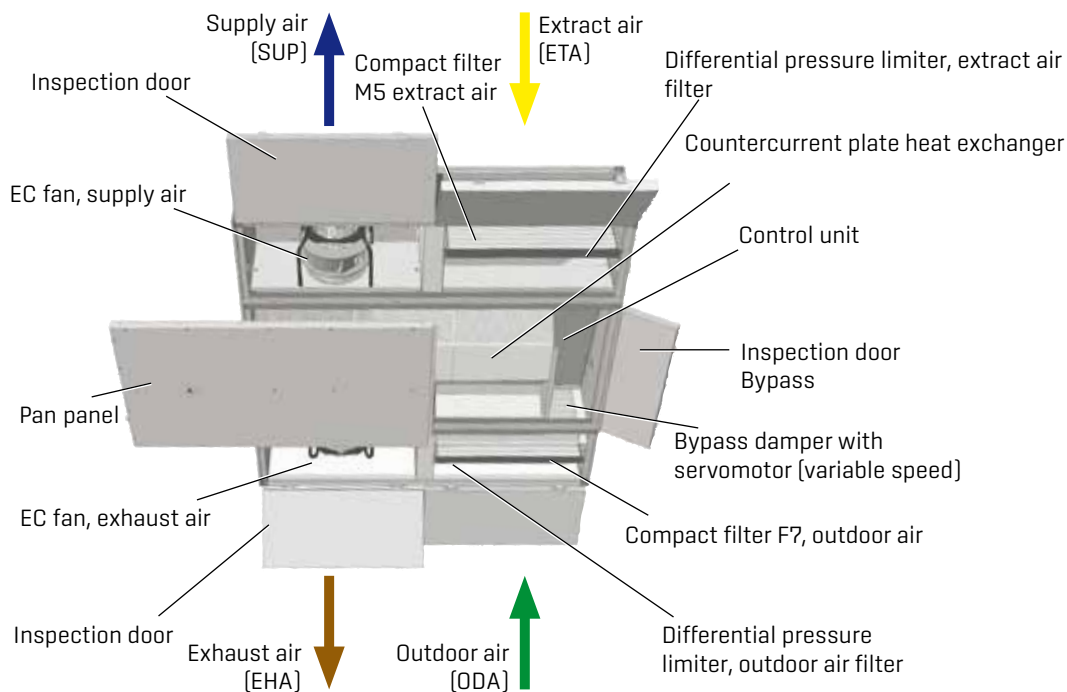

DIMENSIONS

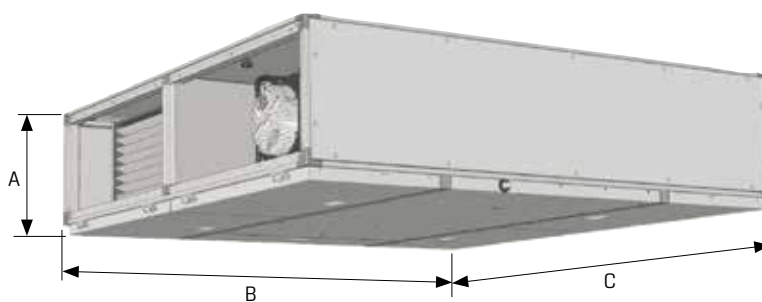

TYPE		CFL32-WRG
Height	A mm	495
Width	B mm	1932
Length	C mm	1932

COMFORT SLIMLINE VENTILATION UNIT CFL-WRG SPECIFICATION

SIZE	CFL	10-WRG	15-WRG	22-WRG	32-WRG
Nominal flow rate	m ³ /h	1000	1500	2200	3200
at available external supply air pressure	Pa	270	380	220	600
at available external extract air pressure	Pa	295	395	170	610
Heat recovery rate	%	> 90	> 90	> 90	> 90
Height	A mm	367	367	411	495
Width	B mm	1017	1423	1830	1932
Length	C mm	1322	1322	1525	1932
Control cabinet width	D mm	115	115	115	-
Internal duct connection dimensions	mm	409 x 247	612 x 247	815 x 291	866 x 354
Weight	kg	130	160	240	340

MOTOR DATA FOR EACH FAN	CFL	10-WRG	15-WRG	22-WRG	32-WRG
Mains voltage	V	1 x 230 V	1 x 230 V	1 x 230 V	3 x 400 V
Frequency	Hz	50 / 60	50 / 60	50 / 60	50 / 60
Max. power consumption	W	480	750	715	1650
Max. current drawn	A	2.1	3.3	3.1	2.5
Speed	rpm	2970	3450	2800	3140
Energy efficiency class		IE 4	IE 4	IE 4	IE 4
IP rating		IP 54	IP 54	IP 54	IP 54
Protection class		Iso B	Iso B	Iso B	Iso B

POWER CABLE	CFL	10-WRG-PWW	15-WRG-PWW	22-WRG-PWW	32-WRG-PWW
Supply voltage	V	1 x 230 V	3 x 400 V	3 x 400 V	3 x 400 V
Cable diameter	mm ²	3 x 1.5 mm ²	5 x 1.5 mm ²	5 x 1.5 mm ²	5 x 2.5 mm ²
On-site fuse/MCB	A	16 A	16 A	16 A	20 A

POWER CABLE	CFL	10-WRG-E-Reg.	15-WRG-E-Reg.	22-WRG-E-Reg.	32-WRG-E-Reg.
Supply voltage	V	1 x 230 V	3 x 400 V	3 x 400 V	3 x 400 V
Cable diameter	mm ²	3 x 1.5 mm ²	5 x 2.5 mm ²	5 x 2.5 mm ²	5 x 6 mm ²
On-site fuse/MCB	A	16 A	20 A	20 A	35 A

COMFORT SLIMLINE VENTILATION UNIT CFL-WRG

COMPONENT DESCRIPTION

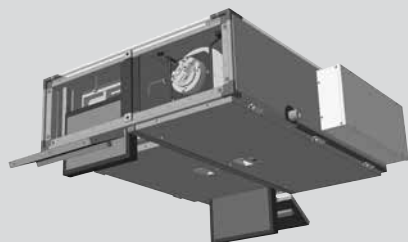

CASING

Compact, inherently stable casing

Casing in duplex design made from zinc-plated sheet steel with thermal insulation sandwiched between the walls

Insulation material is 50 mm thick at the sides and 30 mm in the bottom/top areas
Optimum sound and thermal insulation using mineral wool; material class A1, non-flammable to DIN 4102

Removable inspection doors across the entire surface of the unit, providing optimum access for maintaining the components from below; two additional inspection doors are optionally available to allow easy filter inspection [CFL 10/15/22]

Wiring via cable harness matched to the specific unit and routed in the panels to facilitate easy cleaning

Mounting brackets for ceiling installation (1 set = 4 pce) are included as standard



MOTOR/FAN UNIT FOR SUPPLY AND EXTRACT AIR

Highly efficient [energy efficiency class IE4 to EN 60034-30], free-running impeller fans with single-sided intake, connected directly to the EC motor with low power consumption

Variable speed (0-10 V)

Complete motor / fan unit statically and dynamically balanced

Fan / motor combination with a very low noise level

Fan front plate with integrated installation jig, to simplify maintenance of the motor/fan unit

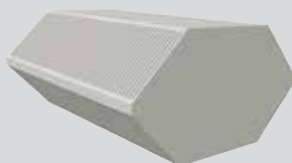

HEAT RECOVERY

Heat recovery via high performance countercurrent plate heat exchanger (PWT)

Heat exchanger made from high grade, corrosion-resistant aluminium

Heat recovery rates up to and exceeding 90 % with low air resistance

Stainless steel pan with drain pipe for draining the condensate

Using a convenient system of fixing rails, plate heat exchangers can be completely removed for inspection

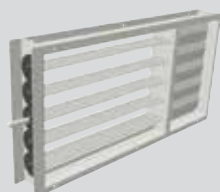

BYPASS

Integral bypass on the air side as standard

In summer, cooling energy can be saved with night ventilation by pre-cooling the rooms for the following day with cool outdoor air.

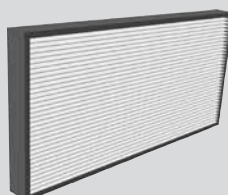

AIR FILTERS

Easily replaceable compact filters which can be removed from below, with large filter surface areas

Supply air: Class F7 as standard (fine dust filter and pollen filter)

Extract air: Class M5 as standard (fine dust filter)

Differential pressure limiter for filter monitoring fitted and wired as standard

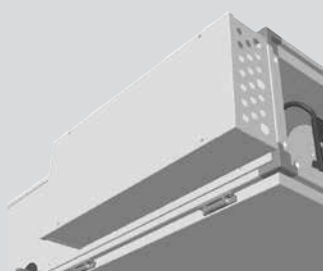

WRS-K CONTROL UNIT

Equipped with WRS-K control unit as standard

WRS-K control unit for booster heating with either PWW or electric heating coil

WRS-K control unit prepared as standard for cooling with PCW coil or direct expansion coil

WRS-K control unit mounted on the side and wired at the factory [CFL 10/15/22], or integrated in the unit [CFL 32]

The microprocessor control unit switches and regulates the fans, heat recovery, temperatures and runtimes, as well as a variety of internal functions and alarms
BMK air conditioning programming unit (can be used as a remote control) is supplied loose as standard

Sensors for outdoor air, supply air, extract air and icing-up, plus 2 differential pressure limiters for filter monitoring fitted inside the unit and wired as standard
Isolator can be optionally integrated in the control cabinet [CFL 10/15/22]

CFL 10/15/22

COMFORT SLIMLINE VENTILATION UNIT CFL-WRG WRS-K CONTROL UNIT

The microprocessor-controlled control unit, with an isolator on the ventilation unit, is fully assembled and wired at the factory. It controls and regulates the fans, heat recovery, temperatures, flow rates and operating times, as well as a variety of internal functions and alarms.

FUNCTION	DESCRIPTION
Languages	Language selection with menu prompts
Preheating program	When outside temperatures are low (adjustable setting), the heating circuit is heated up first when the system is started. This ensures that the heating coil is not damaged and no cold air is blown in when there is a risk of frost.
Backup mode, heating and cooling	In off mode; minimum and maximum room temperature limits are maintained (unoccupied periods)
Night ventilation / cooling function	The building can be cooled to an adjustable set value during the night, using cooler outdoor air (unoccupied periods)
Burner demand via contact	Heat demand to WOLF boilers is issued via the floating contact
Summer compensation	As outside temperatures rise, the set value for the room temperature is adjusted to track the outside temperature
Natural cooling control	If a room needs to be cooled and cool outdoor air is available, this is first used for cooling; if the supply of outdoor air is insufficient, the cooling coil is activated
Fault logging	Date and time of faults are logged (10 messages)
Anti-seizing pump protection	To stop pumps seizing up, they are activated once a week (service function, adjustable start time)
Anti-seizing mixer protection	To stop mixers seizing up, they are activated once a week (service function, adjustable start time)
CO ₂ or VOC control	The speed is adjusted subject to the CO ₂ content of the air
Constant pressure control	Constant pressure control in extract or supply air duct, differential pressure sensor mounted in the unit
Flow rate control	For controlling a constant air volume, differential pressure sensor mounted in the unit
Time program for the day	Setting of 4 day programs, each with 5 switching times with different set values for temperature, speed and pressure
Switching times per day	5 start times and 5 stop times can be set
Filter monitoring (contamination check)	Weekly (adjustable start time, service function), checks the barometric cells for supply and extract air
Fire alarm connection	When fire alarm devices are triggered, the system shuts down (adjustable)
Thermal motor monitoring	Motor monitoring via thermistor
Outdoor/exhaust air damper switching	230 V OPEN/CLOSE switching by controller
Outside temperature sensor	Outside sensor for direct connection to controller (always required)
Supply air temperature control	Supply air is controlled according to the set value.
Supply air - indoor air control	Room temperature control via room sensor
Supply air - extract air control	Room temperature control via extract air sensor
Floating central fault message contact	All accumulating faults are transferred via this contact
Variable valve control, cooling / heating	Control of valve drives with 0-10 V DC
Continuous operation for heating circuit pump	For uninsulated / long pipework
External system start	Remote On / Off
Operating modes	Automatic mode, manual mode, off mode (unoccupied periods), standby (Off)
Infinitely variable motor control	Balance adjustment option for fans (extract air management)
HR, cooling via HR (heat recovery)	PWT (bypass damper control), each with 0 - 10 V DC switching
Electric preheating coil (filter pre-dryer)	Start point + 5 °C
Frost protection function, heating coil (PWW)	Frost stat on the heating coil; when triggered, the fan switches off and the heating coil is purged
Holiday program	Additional time program for the aforementioned operating modes
Summertime / wintertime changeover	Automatically subject to date
PWT de-icing function (ice guard sensor on plate heat exchanger)	When there is a risk of icing-up, the bypass damper is opened and the PWT is de-iced by the flow of warm extract air
Supply air minimum limit	Included in all control unit versions; the supply air temperature does not fall below an adjustable limit
Programming unit with FSTN graphics	The programming unit can also be used as a remote control with display function; connections for BMS on controller

COMFORT SLIMLINE VENTILATION UNIT CFL-WRG
OUTPUT DIAGRAMS
CFL 10-WRG

Exact technical data can only be supplied specific to each project.

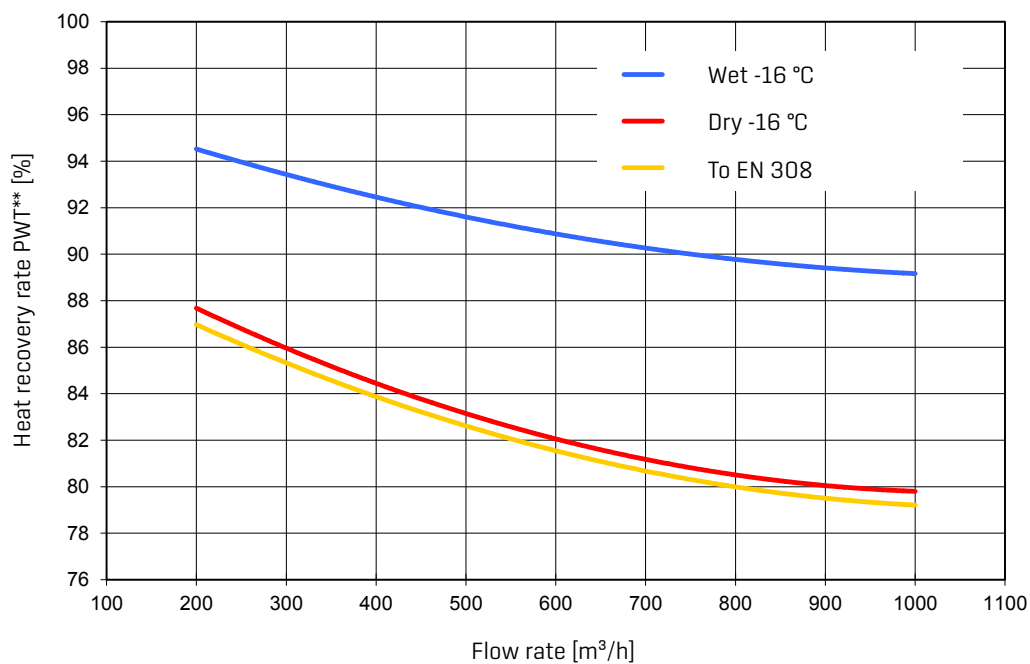
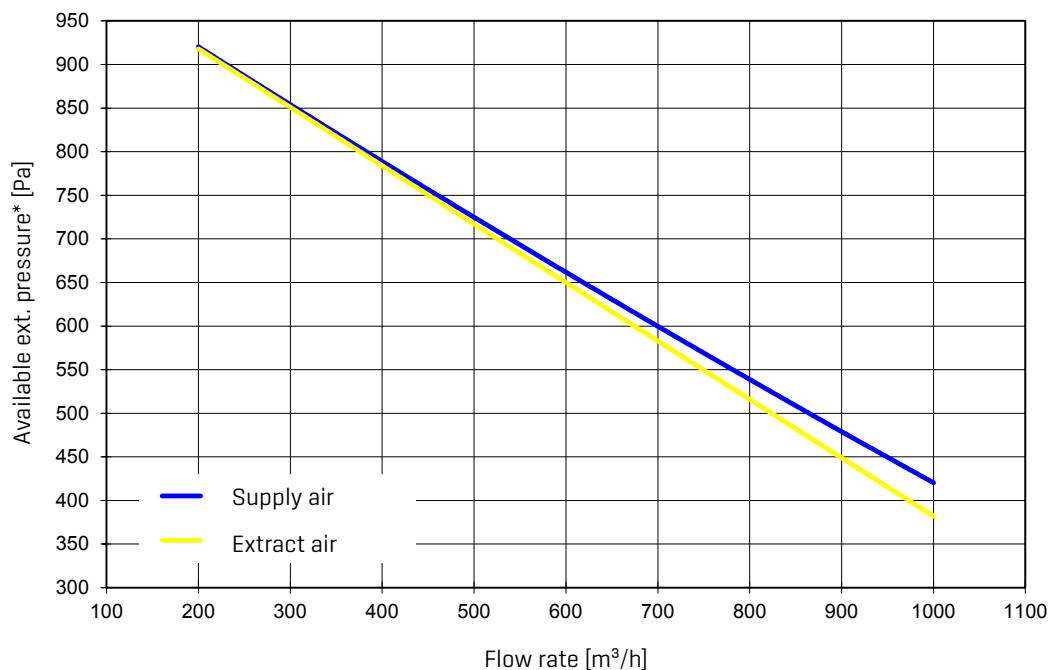

* With free intake and free discharge [without accessories]

** Operating conditions:

\dot{m} 1:1
 ETA +22 °C 40% rel. hum.
 ODA -16 °C
 EN 308 conditions
 ETA +25 °C 25% rel. hum.
 ODA +5 °C

Exact technical data can only be supplied specific to each project.

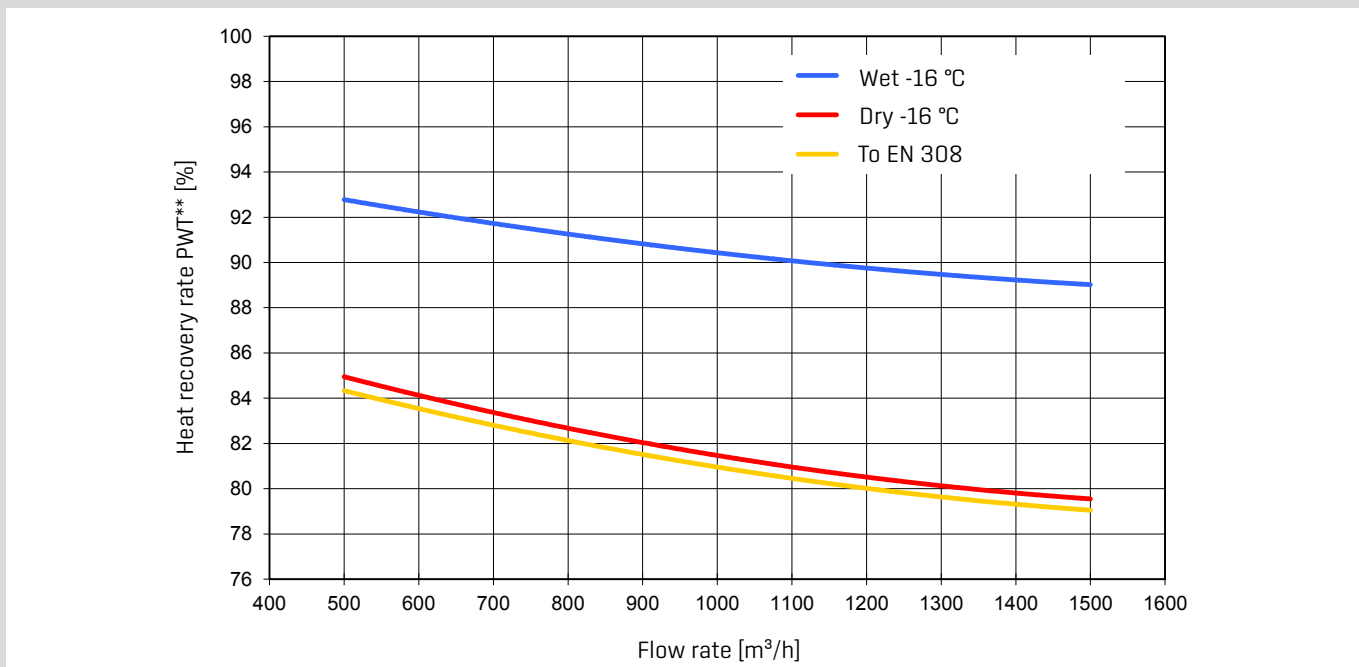
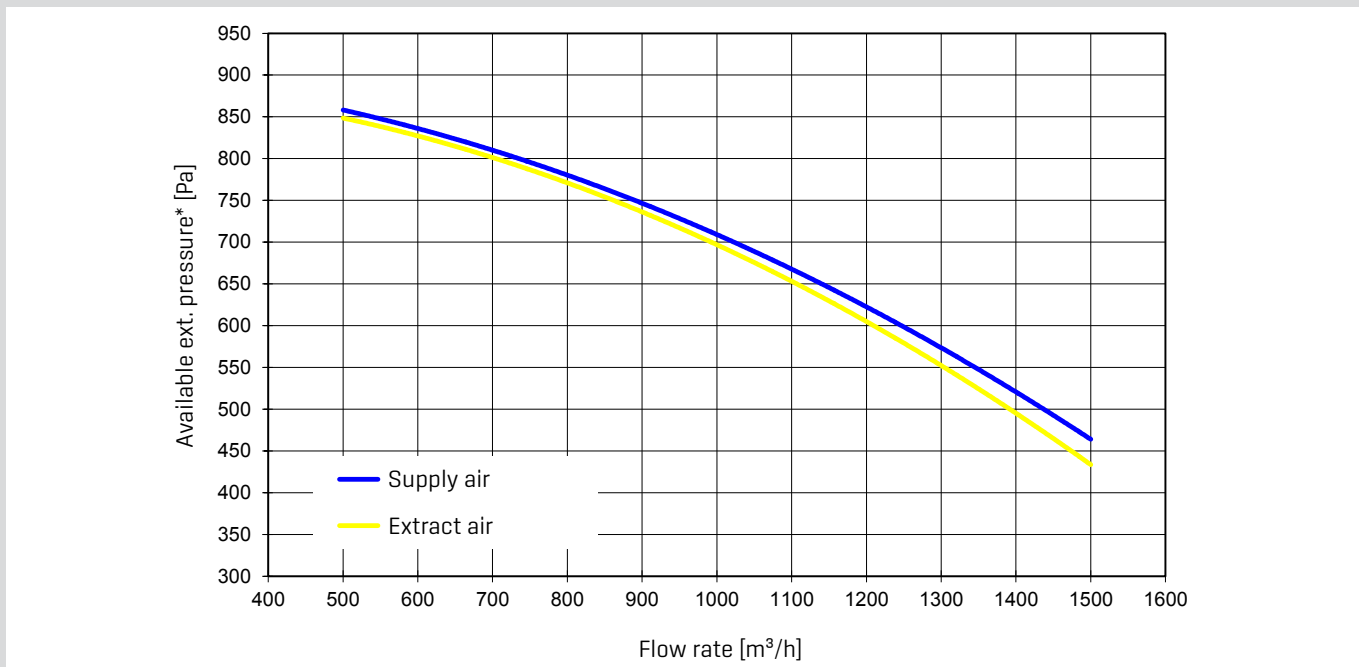

* With free intake and free discharge (without accessories)

** Operating conditions: \dot{m} 1:1
 ETA +22 °C 40 % rel. hum.
 ODA -16 °C
 EN 308 conditions
 ETA +25 °C 25 % rel. hum.
 ODA +5 °C

COMFORT SLIMLINE VENTILATION UNIT CFL-WRG
OUTPUT DIAGRAMS
CFL 22-WRG

Exact technical data can only be supplied specific to each project.

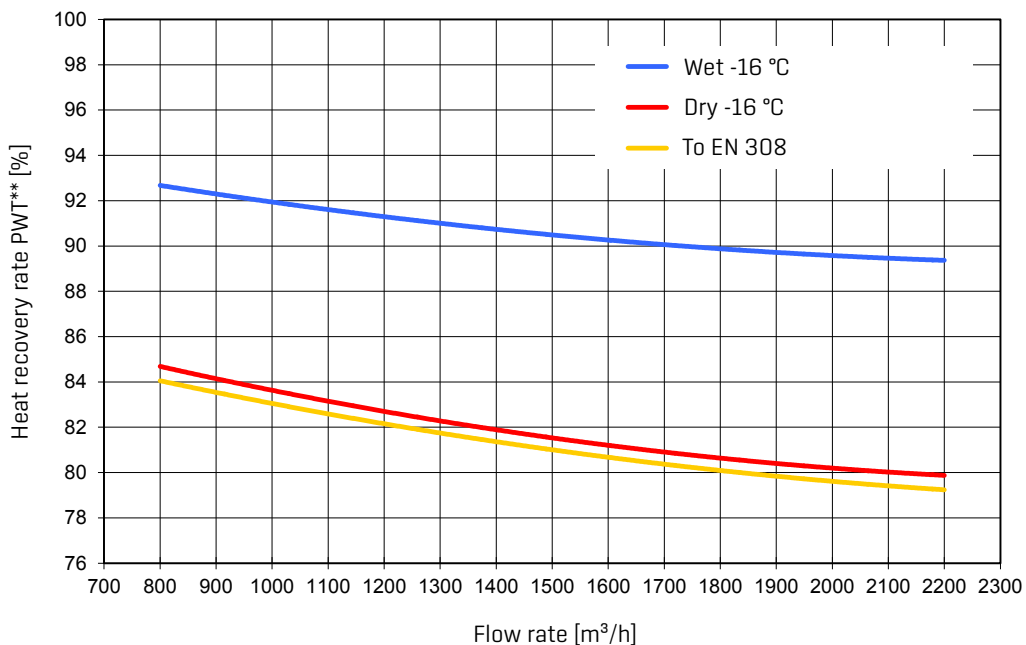
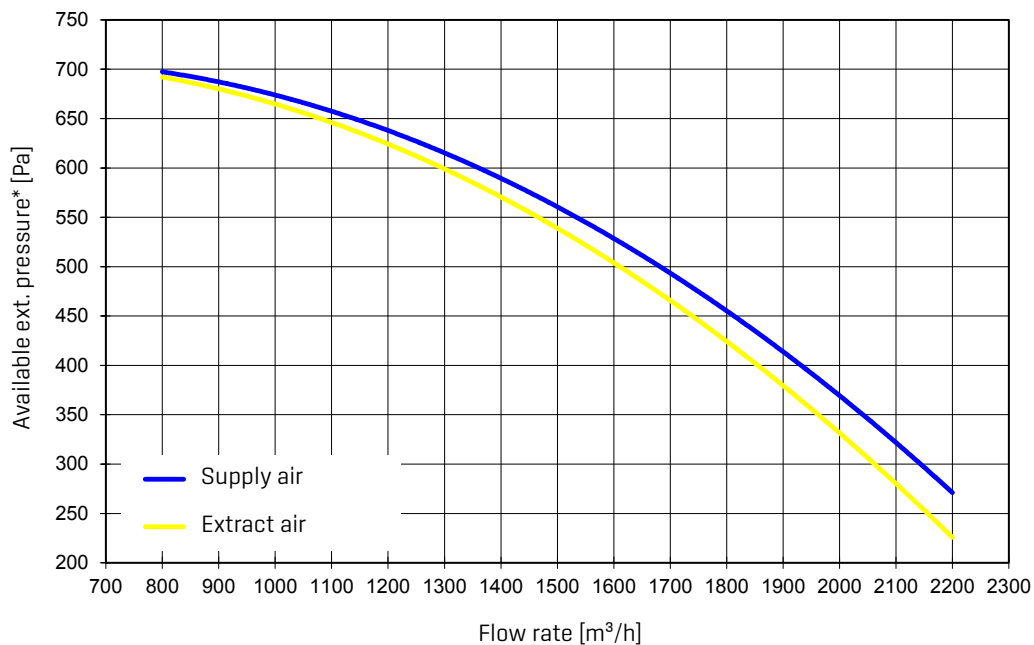

* With free intake and free discharge [without accessories]

** Operating conditions:

\dot{m} 1:1
 ETA +22 °C 40 % rel. hum.
 ODA -16 °C
 EN 308 conditions
 ETA +25 °C 25 % rel. hum.
 ODA +5 °C

Exact technical data can only be supplied specific to each project.

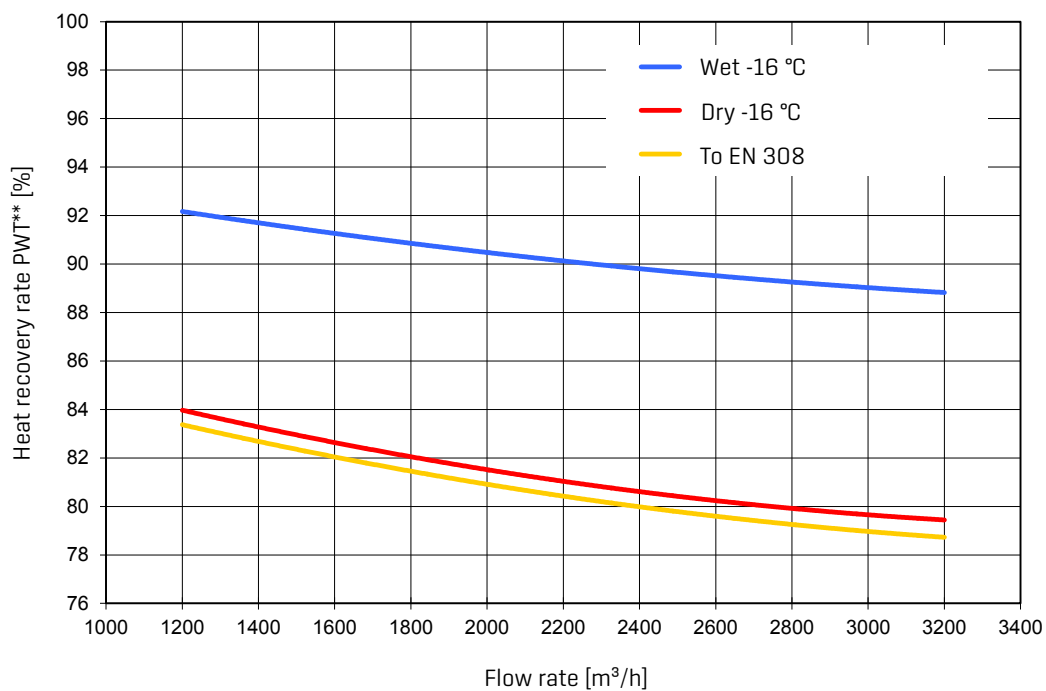
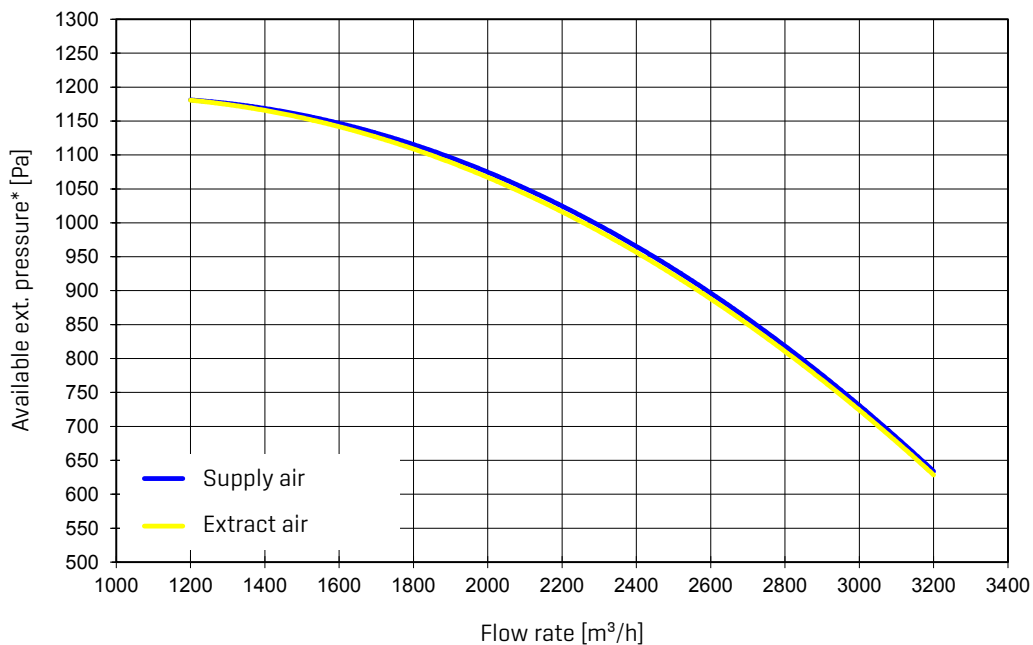

* With free intake and free discharge (without accessories)

** Operating conditions:

\dot{m} 1:1
 ETA +22 °C 40 % rel. hum.
 ODA -16 °C
 EN 308 conditions
 ETA +25 °C 25 % rel. hum.
 ODA +5 °C

COMFORT SLIMLINE VENTILATION UNIT CFL-EC

Fans designed with free-running impellers,
variable speed control with EC technology

Supply and extract air unit in a slimline
design, for ceiling installation and control
from below

Compact dimensions up to 3500 m³/h

Compliant with Hygiene Guideline
VDI 6022

Control unit available as an option

Fans pre-wired to external terminal box,
for fast, straightforward commissioning



9 **BENEFITS OF THE WOLF
COMFORT SLIMLINE
VENTILATION UNIT
CFL-EC**

A wide range of accessories
is available

Supply air units with Cu/Al PWW
heating coil incl. frost protection

Differential pressure limiter for filter
monitoring fitted and wired as standard.

Application range

CFL-EC units are supply air and extract air units in a slimline design for ceiling installation and control from below.

Due to the structure of the units and the components used, the units meet the requirements of regulations on air hygiene in buildings, which are becoming increasingly significant.

CFL supply air units provide rooms with filtered outdoor air in sufficient, infinitely variable amounts. Cu/Al PWW heaters ensure the required room temperatures are reached.

With the help of CFL extract air units, an equally controllable amount of stale indoor air containing CO₂ is removed and expelled as exhaust air. This results in other pollutants such as odours, fine dust, moisture etc. being removed effectively as well. By using the latest EC motor technology, Wolf CFL supply air and extract air units achieve a significant reduction in energy costs.

CFL-EC-ZUL Supply air unit

The diagram shows the unit with the connection side on the right in the supply air direction (connection side on the left in the supply air direction would be the mirror image)

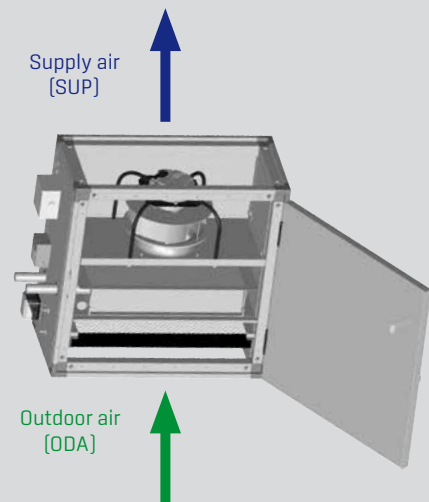

CFL-EC-ABL Extract air unit

The diagram shows the unit with the connection side on the right in the exhaust air direction (connection side on left in the exhaust air direction would be the mirror image)

Note: When combined with extension modules, CFL-EC-ABL units can also be used as particularly space saving supply air units.

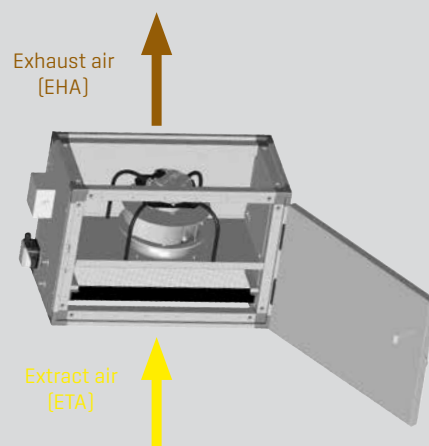

COMFORT SLIMLINE VENTILATION UNIT CFL-EC
SUPPLY AIR UNITS, EXTRACT AIR UNITS

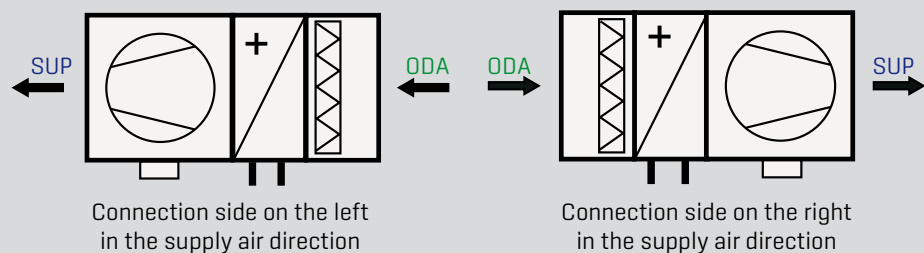

SIZE	TYPE	MAX. AIR VOLUME
CFL-10	EC-ZUL	1300 m ³ /h
CFL-15	EC-ZUL	1800 m ³ /h
CFL-22	EC-ZUL	2600 m ³ /h
CFL-32	EC-ZUL	3500 m ³ /h

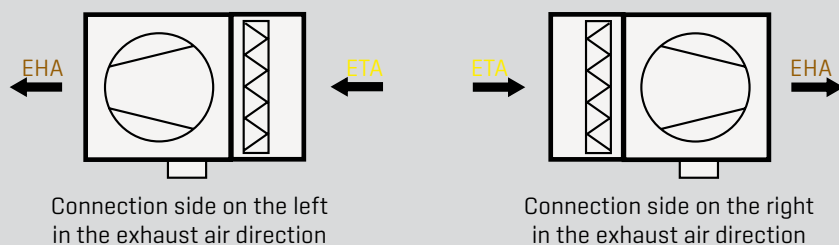

SIZE	TYPE	MAX. AIR VOLUME
CFL-10	EC-ABL	1300 m ³ /h
CFL-15	EC-ABL	1800 m ³ /h
CFL-22	EC-ABL	2600 m ³ /h
CFL-32	EC-ABL	3500 m ³ /h

Note: When combined with extension modules, CFL-EC-ABL units can also be used as particularly space saving supply air units.

COMFORT SLIMLINE VENTILATION UNIT CFL-EC SPECIFICATION

CFL-EC-ZUL
Supply air unit

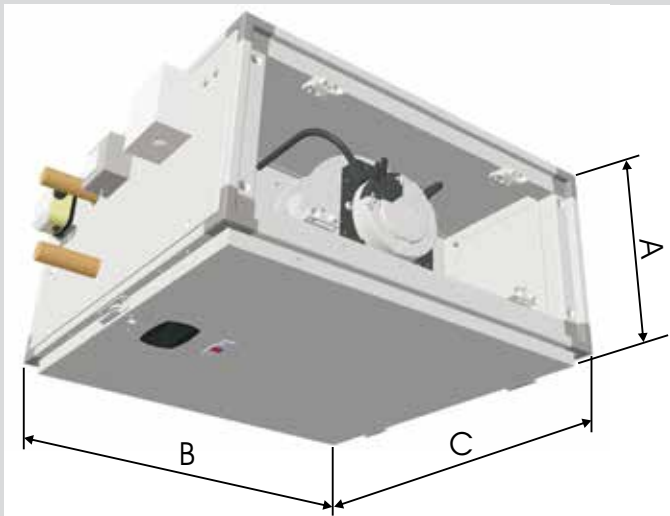

The diagram shows the unit with the connection side on the right in the supply air direction [Connection side on the left in the supply air direction is mirror-inverted]

CFL-EC-ABL
Extract air unit

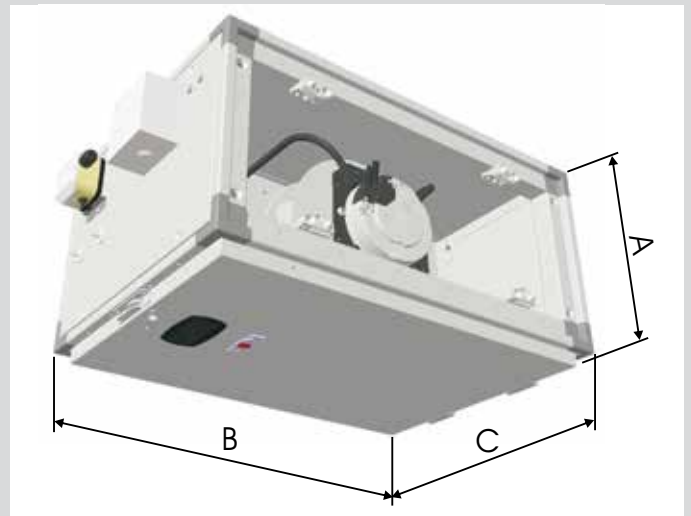

The diagram shows the unit with the connection side on the right in the exhaust air direction [Connection side on left in the exhaust air direction is mirror-inverted]

SIZE	CFL	10-EC-ZUL	15-EC-ZUL	22-EC-ZUL	32-EC-ZUL
Nominal flow rate	m ³ /h	1300	1800	2600	3500
at available external pressure	Pa	310	375	115	660
Height	A mm	367	367	411	495
Width	B mm	508	712	915	966
Length	C mm	712	712	813	813
Terminal box width	mm	61	61	61	61
Internal duct connection dimensions	mm	409 x 247	612 x 247	815 x 291	866 x 354
PWW output [90/70; T _{LE} =0 °C]	kW	18	26	37	51
Weight	kg	47	50	64	82

SIZE	CFL	10-EC-ABL	15-EC-ABL	22-EC-ABL	32-EC-ABL
Nominal flow rate	m ³ /h	1300	1800	2600	3500
at available external pressure	Pa	530	565	305	810
Height	A mm	367	367	411	495
Width	B mm	508	712	915	966
Length	C mm	508	508	610	610
Terminal box width	mm	61	61	61	61
Internal duct connection dimensions	mm	409 x 247	612 x 247	815 x 291	866 x 354
Weight	kg	37	38	48	61

MOTOR DATA FOR EACH FAN	CFL	10-EC	15-EC	22-EC	32-EC
Mains voltage	V	1 x 230 V	1 x 230 V	1 x 230 V	3 x 400 V
Frequency	Hz	50 / 60	50 / 60	50 / 60	50 / 60
Max. power consumption	W	480	750	715	1650
Max. current drawn	A	2.1	3.3	3.1	2.5
Speed	rpm	2070	3450	2800	3140
Energy efficiency class		IE 4	IE 4	IE 4	IE 4
IP rating		IP 54	IP 54	IP 54	IP 54
Protection class		Iso B	Iso B	Iso B	Iso B

COMFORT SLIMLINE VENTILATION UNIT CFL-EC

COMPONENT DESCRIPTION

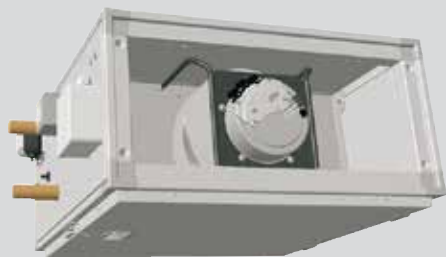

CASING

Compact, inherently stable casing

Casing in duplex design made from zinc-plated sheet steel with thermal insulation sandwiched between the walls

Insulation material is 50 mm thick at the sides and 30 mm in the bottom/top areas

Optimum sound and thermal insulation using mineral wool; material class A1, non-flammable to DIN 4102

Removable inspection door across the entire surface of the unit, giving optimum access for servicing the components from below

Mounting brackets for ceiling installation (1 set = 4 pce) are included as standard



MOTOR/FAN UNIT FOR SUPPLY AND EXTRACT AIR

Highly efficient [energy efficiency class IE4 to EN 60034-30], free-running impeller fans with single-sided intake, connected directly to the EC motor with low power consumption

Variable speed [0-10 V]

Complete motor / fan unit statically and dynamically balanced

Fan / motor combination with a very low noise level

Fan front plate with integrated installation jig, to simplify maintenance of the motor/fan unit

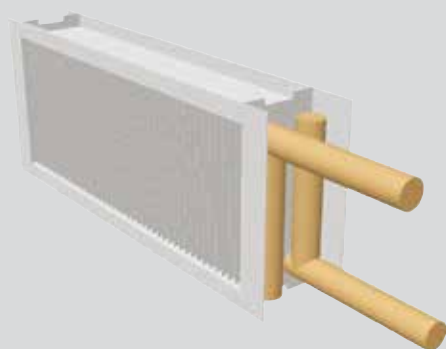

AIR HEATER (ONLY WITH SUPPLY AIR UNIT)

Cu/Al air heater for PWW can be removed from the side

Connections with 1" thread

Incl. frost stat fitted as standard

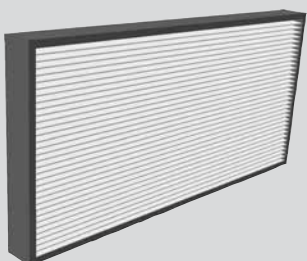

AIR FILTERS

Easily replaceable compact filters which can be removed from below, with large filter surface areas

CFL-EC-ZUL: Class F7 as standard [fine dust filter and pollen filter]

CFL-EC-ABL: Class M5 as standard [fine dust filter]

Differential pressure limiter for filter monitoring fitted and wired as standard

Exact technical data can only be supplied specific to each project.

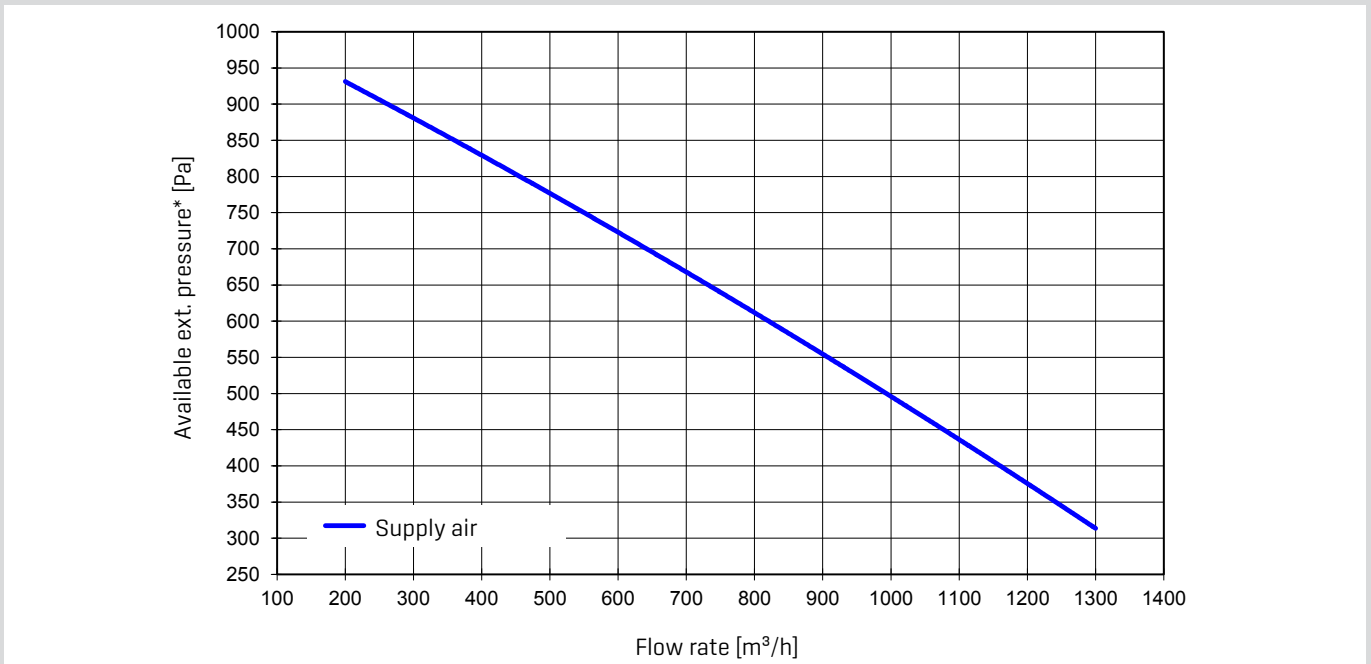

FLOW RATE		400 m³/h		600 m³/h		800 m³/h		1000 m³/h		1300 m³/h	
PWW	Intake temp. [°C]	Output [kW]	Discharge temp. [°C]	Output [kW]	Discharge temp. [°C]	Output [kW]	Discharge temp. [°C]	Output [kW]	Discharge temp. [°C]	Output [kW]	Discharge temp. [°C]
50/40	-15	6.12	25.5	8.21	21.3	10.03	18.2	11.67	15.9	13.89	13.3
	-10	5.54	27.4	7.43	23.5	9.07	20.6	10.54	18.5	12.54	16.1
	-5	4.97	29.2	6.66	25.6	8.12	23.0	9.43	21.0	11.21	18.7
	0	4.41	30.9	5.90	27.6	7.18	25.2	8.34	23.4	9.90	21.4
	5	3.86	32.5	5.15	29.5	6.26	27.4	7.26	25.7	8.60	23.9
	10	3.31	34.1	4.41	31.3	5.35	29.4	6.19	28.0	7.33	26.4
	15	2.77	35.5	3.67	33.1	4.45	31.5	5.14	30.2	6.08	28.8
20	2.24	36.8	2.95	34.8	3.56	33.4	4.11	32.4	4.84	31.2	
60/50	-15	7.19	32.6	9.69	27.8	11.88	24.4	13.85	21.7	16.51	18.7
	-10	6.61	34.6	8.90	30.1	10.90	26.8	12.71	24.3	15.15	21.5
	-5	6.03	36.6	8.12	32.3	9.95	29.2	11.58	26.9	13.80	24.2
	0	5.47	38.4	7.36	34.4	9.00	31.6	10.48	29.4	12.47	26.9
	5	4.92	40.1	6.60	36.4	8.07	33.8	9.39	31.8	11.17	29.5
	10	4.37	41.8	5.86	38.4	7.15	36.0	8.31	34.2	9.88	32.1
	15	3.83	43.3	5.12	40.3	6.24	38.1	7.25	36.4	8.61	34.6
20	3.29	44.8	4.40	42.0	5.35	40.1	6.20	38.7	7.35	37.0	
90/70	-15	9.55	48.3	12.88	41.9	15.79	37.3	18.41	33.8	21.95	29.8
	-10	8.97	50.6	12.09	44.4	14.81	40.0	17.25	36.6	20.56	32.8
	-5	8.39	52.8	11.30	46.9	13.84	42.6	16.12	39.4	19.20	35.7
	0	7.82	54.9	10.53	49.2	12.88	45.2	14.99	42.1	17.85	38.5
	5	7.26	56.9	9.76	51.5	11.94	47.6	13.89	44.7	16.53	41.3
	10	6.71	58.8	9.01	53.7	11.00	50.0	12.80	47.2	15.22	44.0
	15	6.16	60.6	8.26	55.7	10.09	52.3	11.72	49.7	13.92	46.7
20	5.63	62.3	7.53	57.8	9.18	54.5	10.65	52.1	12.65	49.3	

* With free intake and free discharge (without accessories)

COMFORT SLIMLINE VENTILATION UNIT

OUTPUT DIAGRAMS

CFL 15-EC-ZUL

Exact technical data can only be supplied specific to each project.

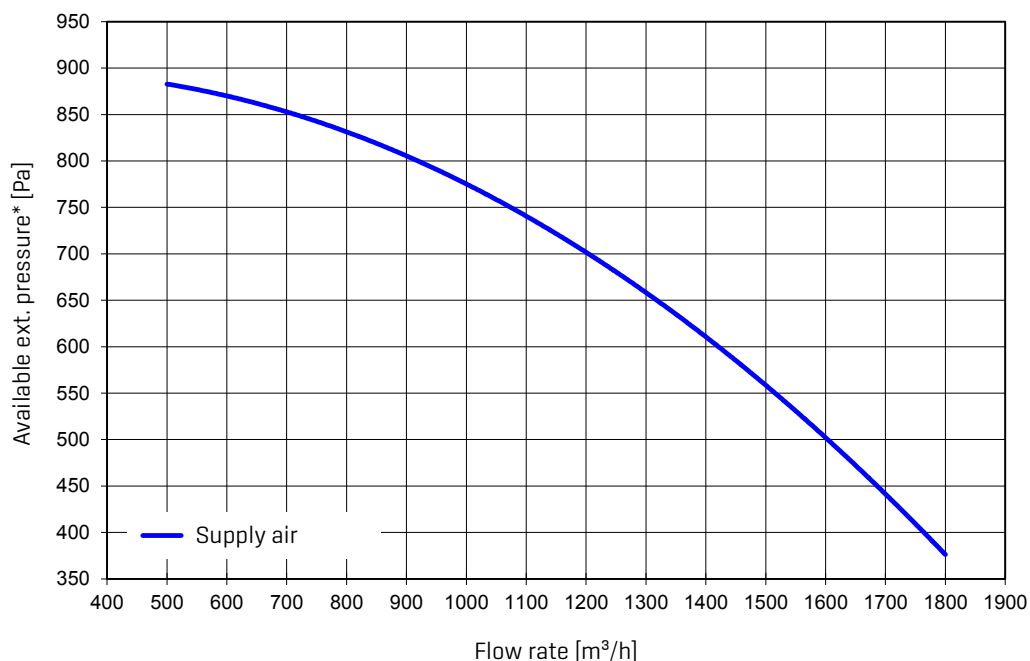

FLOW RATE		750 m³/h		1000 m³/h		1250 m³/h		1500 m³/h		1800 m³/h	
PWW	Intake temp. [°C]	Output [kW]	Discharge temp. [°C]	Output [kW]	Discharge temp. [°C]	Output [kW]	Discharge temp. [°C]	Output [kW]	Discharge temp. [°C]	Output [kW]	Discharge temp. [°C]
50/40	-15	11.02	23.9	13.55	20.9	15.82	18.6	17.91	16.7	20.24	14.8
	-10	9.97	25.9	12.25	23.1	14.3	20.9	16.18	19.2	18.27	17.4
	-5	8.94	27.8	10.97	25.2	12.8	23.2	14.48	21.6	16.34	20
	0	7.93	29.7	9.72	27.3	11.32	25.4	12.8	23.9	14.43	22.5
	5	6.93	31.4	8.47	29.2	9.87	27.5	11.14	26.2	12.55	24.9
	10	5.94	33	7.25	31.1	8.43	29.6	9.51	28.4	10.7	27.3
	15	4.96	34.6	6.04	32.9	7.01	31.6	7.9	30.6	8.87	29.6
	20	3.99	36	4.85	34.6	5.61	33.5	6.3	32.6	7.07	31.8
60/50	-15	12.97	30.9	16	27.4	18.73	24.7	21.25	22.6	24.05	20.4
	-10	11.92	33	14.69	29.7	17.2	27.2	19.5	25.1	22.06	23.1
	-5	10.88	35	13.41	31.9	15.68	29.6	17.78	27.6	20.1	25.8
	0	9.86	36.9	12.14	34.1	14.19	31.9	16.08	30.1	18.17	28.3
	5	8.86	38.7	10.89	36.1	12.72	34.1	14.4	32.4	16.27	30.8
	10	7.86	40.5	9.66	38.1	11.27	36.2	12.75	34.7	14.4	33.3
	15	6.88	42.1	8.44	40	9.84	38.3	11.12	36.9	12.55	35.6
	20	5.91	43.7	7.24	41.8	8.43	40.3	9.52	39.1	10.72	37.9
90/70	-15	12.97	30.9	16	27.4	18.73	24.7	21.25	22.6	24.05	20.4
	-10	11.92	33	14.69	29.7	17.2	27.2	19.5	25.1	22.06	23.1
	-5	10.88	35	13.41	31.9	15.68	29.6	17.78	27.6	20.1	25.8
	0	9.86	36.9	12.14	34.1	14.19	31.9	16.08	30.1	18.17	28.3
	5	8.86	38.7	10.89	36.1	12.72	34.1	14.4	32.4	16.27	30.8
	10	7.86	40.5	9.66	38.1	11.27	36.2	12.75	34.7	14.4	33.3
	15	6.88	42.1	8.44	40	9.84	38.3	11.12	36.9	12.55	35.6
	20	5.91	43.7	7.24	41.8	8.43	40.3	9.52	39.1	10.72	37.9

* With free intake and free discharge [without accessories]

Exact technical data can only be supplied specific to each project.

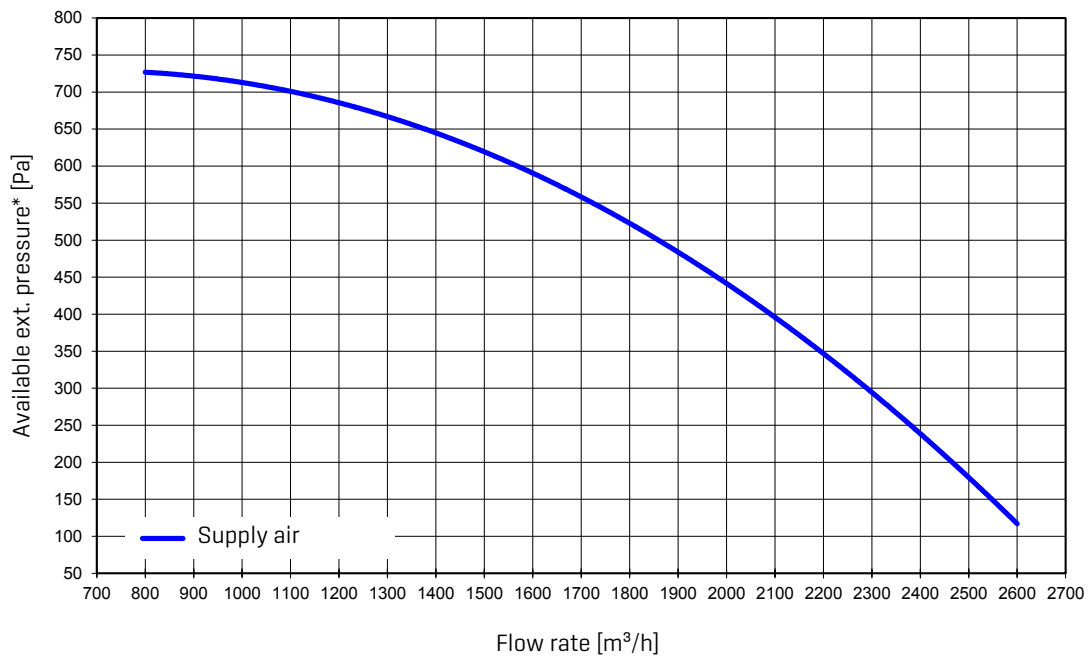

FLOW RATE		1000 m³/h		1400 m³/h		1800 m³/h		2200 m³/h		2600 m³/h	
PWW	Intake temp. [°C]	Output [kW]	Discharge temp. [°C]	Output [kW]	Discharge temp. [°C]	Output [kW]	Discharge temp. [°C]	Output [kW]	Discharge temp. [°C]	Output [kW]	Discharge temp. [°C]
50/40	-15	14.81	24.3	18.84	20.7	22.4	18	25.65	15.9	28.64	14.2
	-10	13.43	26.3	17.07	23	20.29	20.5	23.22	18.5	25.93	16.9
	-5	12.07	28.3	15.33	25.2	18.21	22.9	20.83	21.1	23.24	19.6
	0	10.74	30.1	13.62	27.3	16.16	25.2	18.47	23.6	20.6	22.2
	5	9.41	31.9	11.92	29.3	14.14	27.4	16.15	26	18	24.8
	10	8.11	33.6	10.25	31.3	12.14	29.6	13.85	28.3	15.43	27.3
	15	6.82	35.2	8.6	33.2	10.17	31.7	11.59	30.6	12.89	29.7
	20	5.55	36.7	6.97	35	8.22	33.7	9.35	32.8	10.38	32
60/50	-15	17.35	31	22.14	26.9	26.39	23.9	30.26	21.5	33.84	19.5
	-10	15.96	33.1	20.36	29.3	24.26	26.4	27.81	24.2	31.09	22.3
	-5	14.6	35.2	18.61	31.6	22.16	28.9	25.4	26.8	28.38	25.1
	0	13.25	37.2	16.88	33.8	20.09	31.3	23.02	29.4	25.72	27.8
	5	11.93	39.1	15.18	36	18.05	33.7	20.67	31.8	23.08	30.4
	10	10.62	40.9	13.49	38	16.04	35.9	18.35	34.3	20.49	32.9
	15	9.32	42.6	11.84	40	14.05	38.1	16.07	36.6	17.92	35.4
	20	8.05	44.2	10.2	41.9	12.09	40.2	13.81	38.9	15.39	37.8
90/70	-15	23.12	46.3	29.52	40.9	35.2	36.8	40.36	33.6	45.14	31
	-10	21.72	48.7	27.72	43.5	33.04	39.6	37.88	36.5	42.35	34
	-5	20.34	51	25.95	46	30.92	42.3	35.43	39.4	39.6	37
	0	18.99	53.3	24.2	48.5	28.82	44.9	33.02	42.1	36.89	39.8
	5	17.65	55.4	22.47	50.9	26.75	47.5	30.63	44.8	34.22	42.6
	10	16.32	57.5	20.77	53.1	24.71	49.9	28.29	47.4	31.58	45.3
	15	15.02	59.4	19.09	55.3	22.69	52.3	25.96	49.9	28.98	48
	20	13.72	61.3	17.43	57.5	20.7	54.6	23.67	52.4	26.4	50.6

* With free intake and free discharge (without accessories)

COMFORT SLIMLINE VENTILATION UNIT

OUTPUT DIAGRAMS

CFL 32-EC-ZUL

Exact technical data can only be supplied specific to each project.

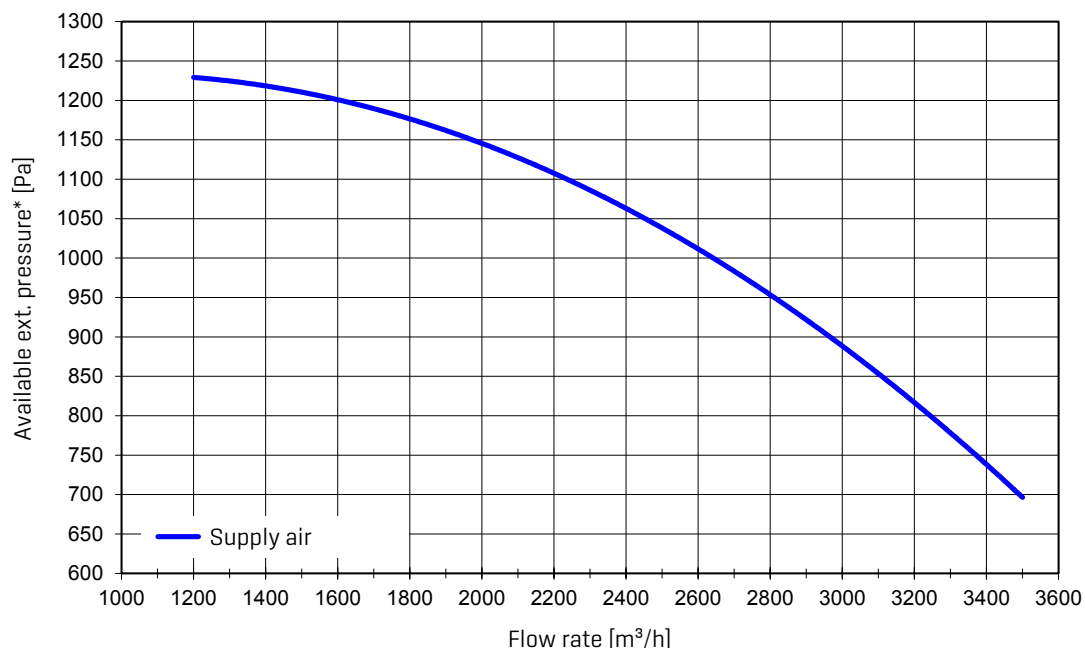

* With free intake and free discharge [without accessories]

FLOW RATE		2000 m³/h		2400 m³/h		2800 m³/h		3200 m³/h		3500 m³/h	
PWW	Intake temp. [°C]	Output [kW]	Discharge temp. [°C]	Output [kW]	Discharge temp. [°C]	Output [kW]	Discharge temp. [°C]	Output [kW]	Discharge temp. [°C]	Output [kW]	Discharge temp. [°C]
50/40	-15	27.04	20.8	30.68	18.9	34.07	17.3	37.26	15.9	39.54	15
	-10	24.53	23.1	27.82	21.3	30.88	19.8	33.77	18.5	35.83	17.7
	-5	22.05	25.4	25	23.7	27.75	22.3	30.33	21.1	32.17	20.3
	0	19.61	27.5	22.22	26	24.65	24.7	26.93	23.6	28.56	22.9
	5	17.2	29.6	19.48	28.2	21.6	27	23.58	26.1	25	25.4
	10	14.82	31.6	16.77	30.3	18.58	29.3	20.28	28.4	21.49	27.9
	15	12.47	33.5	14.1	32.4	15.6	31.5	17.02	30.7	18.02	30.2
60/50	20	10.15	35.3	11.45	34.4	12.66	33.6	13.79	33	14.59	32.6
	-15	31.7	27	36.02	24.8	40.05	22.9	43.85	21.3	46.56	20.3
	-10	29.17	29.4	33.14	27.3	36.84	25.6	40.33	24.1	42.82	23.1
	-5	26.68	31.7	30.3	29.8	33.68	28.1	36.85	26.7	39.12	25.8
	0	24.22	34	27.5	32.2	30.56	30.6	33.43	29.3	35.48	28.5
	5	21.8	36.1	24.74	34.5	27.48	33	30.05	31.8	31.89	31
	10	19.41	38.2	22.01	36.7	24.44	35.4	26.72	34.3	28.35	33.6
90/70	15	17.05	40.2	19.32	38.8	21.44	37.7	23.43	36.7	24.85	36
	20	14.71	42.1	16.67	40.9	18.48	39.9	20.18	39	21.4	38.4
	-15	42.32	41.1	48.11	38.1	53.5	35.7	58.57	33.5	62.2	32.1
	-10	39.76	43.7	45.19	40.9	50.25	38.5	55	36.5	58.4	35.1
	-5	37.24	46.3	42.31	43.6	47.04	41.3	51.48	39.3	54.65	38
	0	34.76	48.8	39.48	46.2	43.87	44	48	42.1	50.96	40.9
	5	32.3	51.1	36.68	48.7	40.75	46.6	44.57	44.8	47.31	43.6
10	29.88	53.4	33.91	51.1	37.66	49.1	41.19	47.4	43.71	46.3	
15	27.49	55.7	31.18	53.4	34.62	51.6	37.85	50	40.15	48.9	
20	25.12	57.8	28.48	55.7	31.61	54	34.54	52.5	36.64	51.5	

COMFORT SLIMLINE VENTILATION UNIT
OUTPUT DIAGRAMS
CFL 10-EC-ABL

Exact technical data can only be supplied specific to each project.

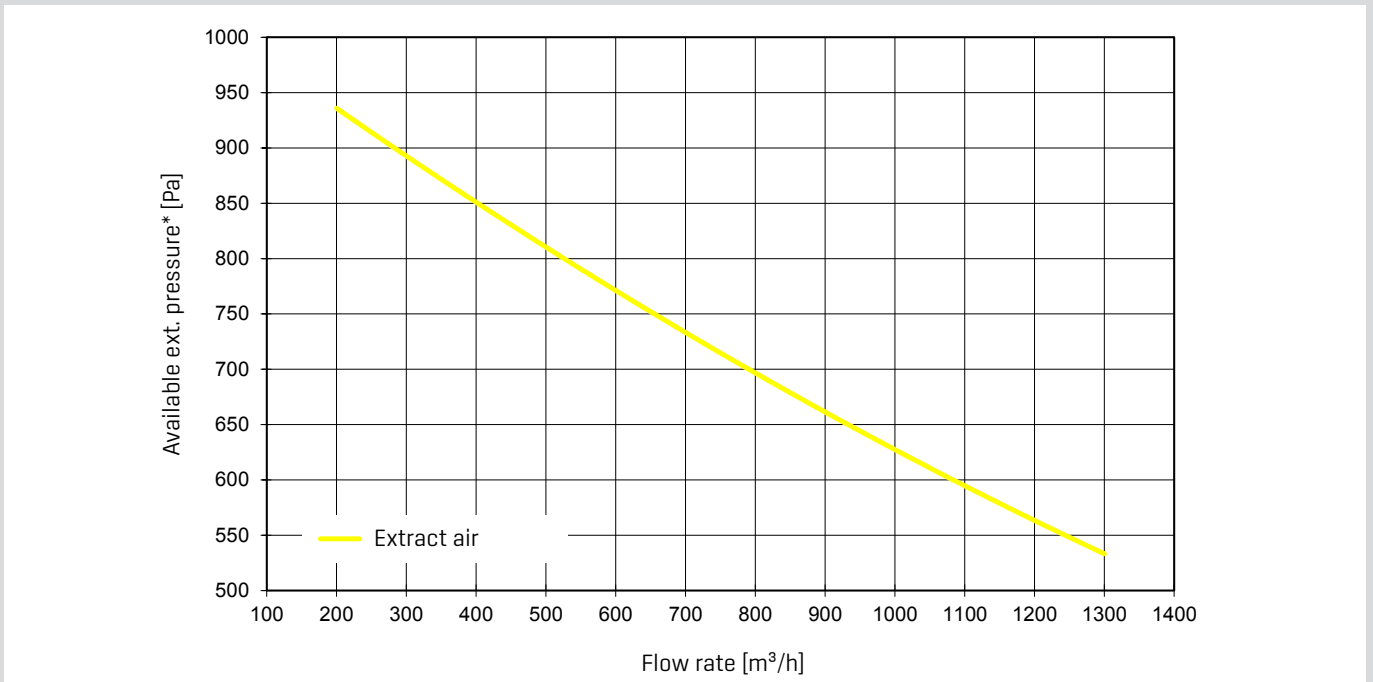

* With free intake and free discharge [without accessories]

COMFORT SLIMLINE VENTILATION UNIT
OUTPUT DIAGRAMS
CFL 15-EC-ABL

Exact technical data can only be supplied specific to each project.

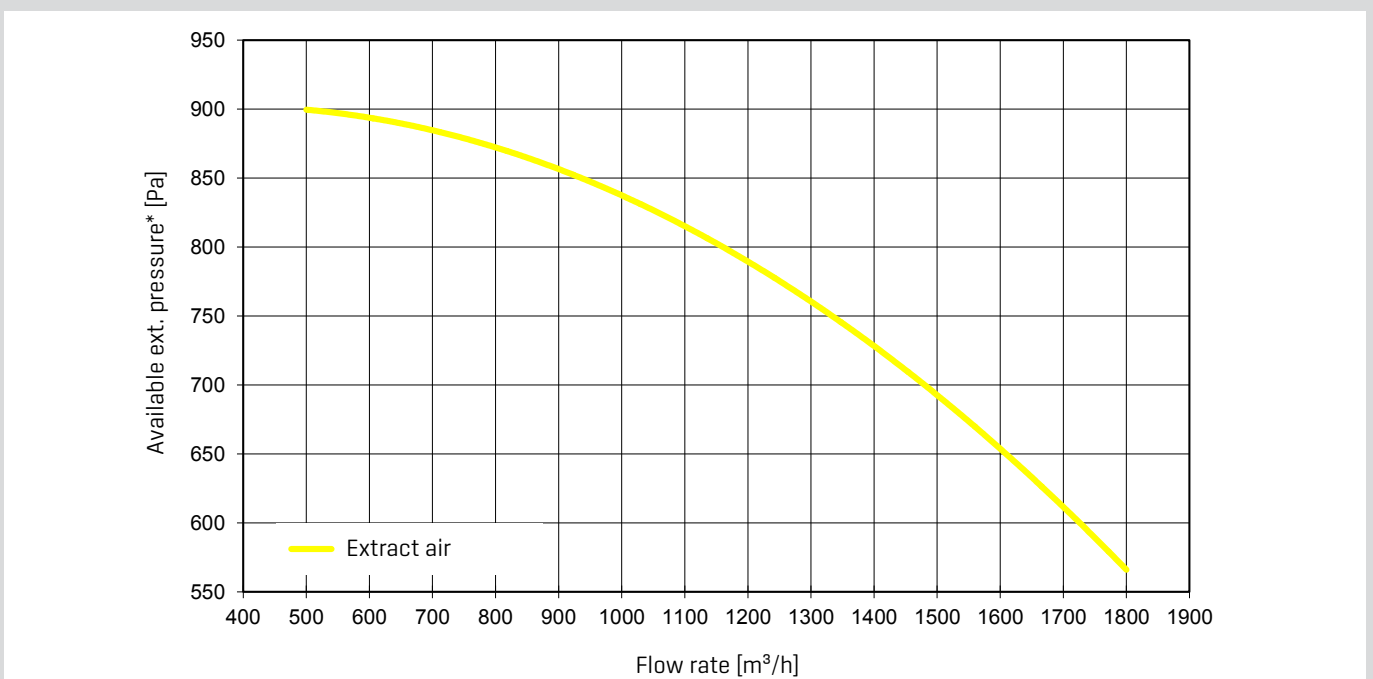

* With free intake and free discharge [without accessories]

COMFORT SLIMLINE VENTILATION UNIT
OUTPUT DIAGRAMS
CFL 22-EC-ABL

Exact technical data can only be supplied specific to each project.

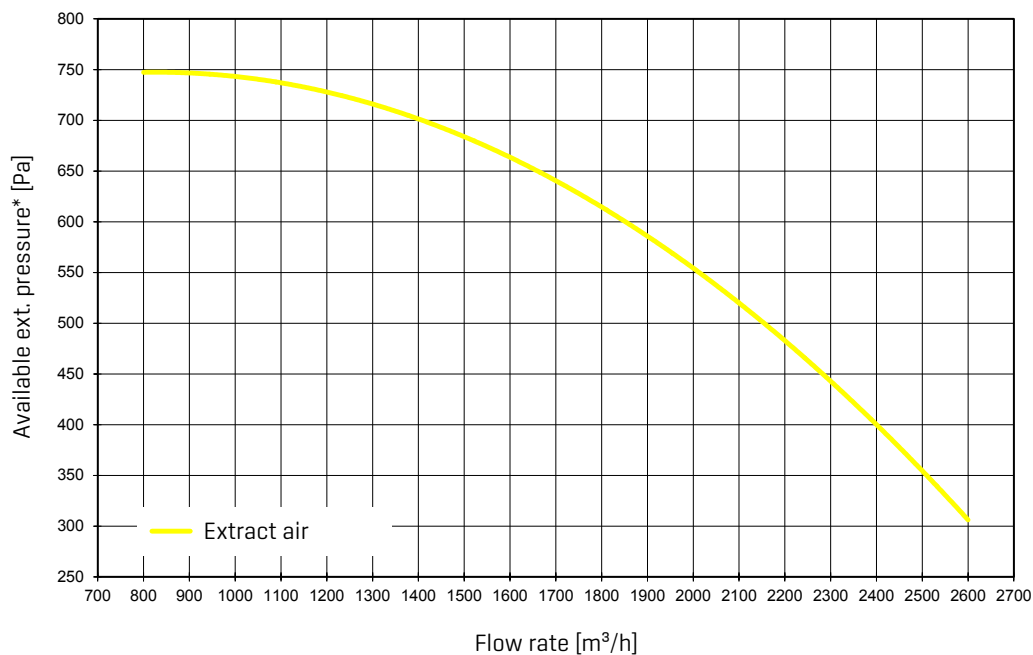

* With free intake and free discharge [without accessories]

COMFORT SLIMLINE VENTILATION UNIT
OUTPUT DIAGRAMS
CFL 32-EC-ABL

Exact technical data can only be supplied specific to each project.

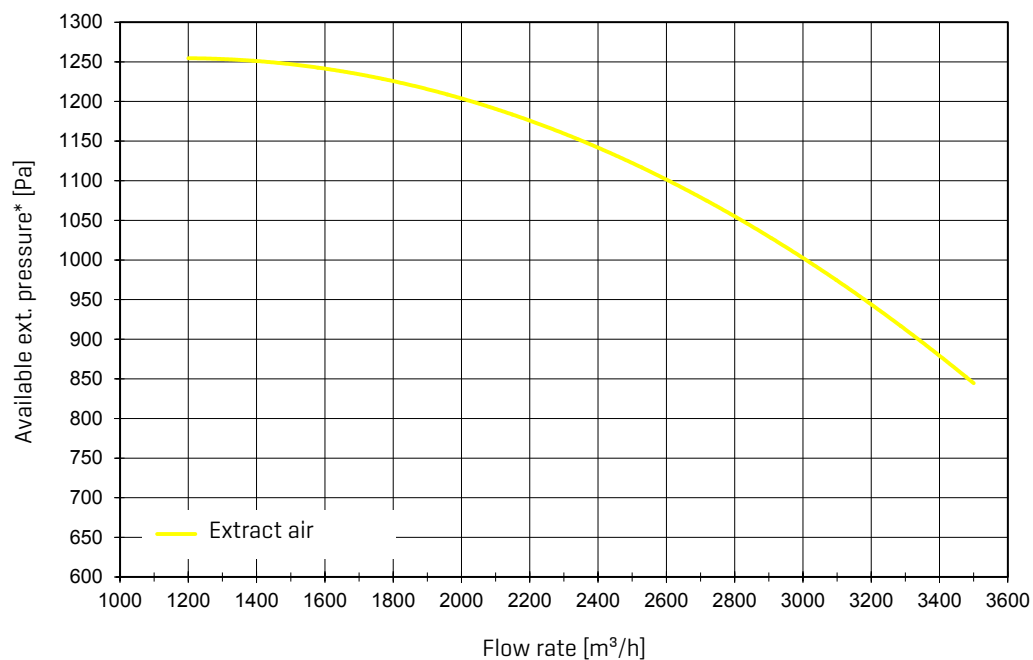

* With free intake and free discharge [without accessories]

COMFORT SLIMLINE VENTILATION UNIT CFL ACCESSORIES



EXTENSION MODULE, PCW COOLING COIL

- Optional, for mounting on the unit, available with connection side on the left or right in the direction of airflow
- Can be combined with CFL-WRG, CFL-EC-ZUL and CFL-EC-ABL
- Cu/Al air cooler for PCW, removable from the side
- 3/4" thread connections
- Supply air temperature sensor optionally available (loose)
- Incl. 1 set of mounting brackets [2 pce]
- Filter insertion slot for compact filters with fine dust quality M5 /F7 / F9
- Inspection door allows access to the filter

Size	CFL	10	15
Dimensions [LxWxH]	mm	712 x 508 x 367	712 x 712 x 367
Max. air volume	m³/h	1000	1800

CFL 10

FLOW RATE			400 m³/h		550 m³/h		700 m³/h		850 m³/h		1000 m³/h	
PCW	Intake temp. [°C]	rel. hum. [%]	Output [kW]	Discharge temp. [°C]	Output [kW]	Discharge temp. [°C]	Output [kW]	Discharge temp. [°C]	Output [kW]	Discharge temp. [°C]	Output [kW]	Discharge temp. [°C]
4/8	32	40	3.5	13.8	4.4	15.2	5.2	16.3	6.0	17.2	6.7	17.9
	30	45	3.3	13.6	4.1	15.0	4.9	16.0	5.6	16.8	6.2	17.5
	28	50	3.1	13.4	3.8	14.6	4.5	15.6	5.1	16.3	5.7	16.9
	26	50	2.7	12.3	3.3	13.5	4.0	14.3	4.5	15.0	5.0	15.5
	24	50	2.3	11.3	2.9	12.3	3.4	13.1	3.9	13.7	4.3	14.2
5/10	32	40	3.2	14.8	4.0	16.1	4.7	17.2	5.4	18.0	6.0	18.7
	30	45	3.0	14.7	3.7	15.9	4.4	16.9	5.0	17.6	5.5	18.3
	28	50	2.7	14.4	3.4	15.6	4.0	16.5	4.5	17.1	5.0	17.7
	26	50	2.3	13.3	2.9	14.4	3.4	15.2	3.9	15.8	4.4	16.3
	24	50	2.0	12.3	2.5	13.2	2.9	13.9	3.3	14.4	3.7	14.9
6/12	32	40	2.9	15.7	3.6	17.0	4.2	17.9	4.8	18.7	5.3	19.3
	30	45	2.6	15.6	3.3	16.8	3.9	17.7	4.4	18.4	4.9	18.9
	28	50	2.4	15.4	3.0	16.5	3.5	17.3	4.0	17.9	4.4	18.4
	26	50	2.0	14.3	2.5	15.2	2.9	15.9	3.3	16.5	3.7	16.9
	24	50	1.6	13.1	2.0	13.9	2.4	14.5	2.7	15.0	3.0	15.4

CFL 15

FLOW RATE			750 m³/h		1000 m³/h		1250 m³/h		1500 m³/h		1800 m³/h	
PCW	Intake temp. [°C]	rel. hum. [%]	Output [kW]	Discharge temp. [°C]	Output [kW]	Discharge temp. [°C]	Output [kW]	Discharge temp. [°C]	Output [kW]	Discharge temp. [°C]	Output [kW]	Discharge temp. [°C]
4/8	32	40	6.9	13.0	8.6	14.3	10.0	15.3	11.4	16.2	12.9	17.0
	30	45	6.5	12.9	8.0	14.1	9.4	15.1	10.6	15.8	12.0	16.6
	28	50	6.0	12.7	7.4	13.8	8.7	14.7	9.8	15.4	11.1	16.1
	26	50	5.3	11.7	6.5	12.7	7.6	13.5	8.6	14.2	9.7	14.8
	24	50	4.5	10.7	5.6	11.7	6.5	12.4	7.4	13.0	8.4	13.5
5/10	32	40	6.3	14.0	7.8	15.2	9.1	16.2	10.3	17.0	11.7	17.8
	30	45	5.9	13.9	7.2	15.1	8.4	16.0	9.6	16.7	10.8	17.5
	28	50	5.4	13.8	6.6	14.8	7.7	15.6	8.7	16.3	9.8	17.0
	26	50	4.6	12.7	5.7	13.7	6.7	14.4	7.5	15.0	8.5	15.6
	24	50	3.9	11.7	4.8	12.6	5.6	13.2	6.3	13.8	7.2	14.3
6/12	32	40	5.7	15.0	7.0	16.1	8.1	17.0	9.2	17.8	10.4	18.5
	30	45	5.2	14.9	6.4	16.0	7.5	16.8	8.5	17.5	9.6	18.2
	28	50	4.8	14.7	5.8	15.7	6.8	16.5	7.7	17.1	8.6	17.7
	26	50	4.0	13.7	4.9	14.5	5.7	15.2	6.5	15.8	7.3	16.3
	24	50	3.3	12.6	4.0	13.4	4.7	13.9	5.3	14.4	5.9	14.9



COMFORT SLIMLINE VENTILATION UNIT CFL

ACCESSORIES



EXTENSION MODULE, PCW COOLING COIL

- Optional, for mounting on the unit, available with connection side on the left or right in the direction of airflow
- Can be combined with CFL-WRG, CFL-EC-ZUL and CFL-EC-ABL
- Cu/Al air cooler for PCW, removable from the side
- 3/4" thread connections
- Supply air temperature sensor optionally available (loose)
- Incl. 1 set of mounting brackets (2 pce)
- Filter insertion slot for compact filters with fine dust quality M5 /F7 / F9
- Inspection door allows access to the filter

Size	CFL	22	32
Dimensions [LxWxH]	mm	712 x 915 x 411	813 x 966 x 495
Max. air volume	m ³ /h	2600	3500

CFL 22

FLOW RATE			1000 m ³ /h		1400 m ³ /h		1800 m ³ /h		2200 m ³ /h		2600 m ³ /h	
PCW	Intake temp. [°C]	rel. hum. [%]	Output [kW]	Discharge temp. [°C]	Output [kW]	Discharge temp. [°C]	Output [kW]	Discharge temp. [°C]	Output [kW]	Discharge temp. [°C]	Output [kW]	Discharge temp. [°C]
4/8	32	40	9.3	12.9	12	14.5	14.3	15.6	16.4	16.6	18.4	17.3
	30	45	8.8	12.8	11.2	14.3	13.4	15.3	15.3	16.2	17.1	16.9
	28	50	8.1	12.6	10.3	13.9	12.3	14.9	14.1	15.7	15.8	16.3
	26	50	7.1	11.6	9.1	12.8	10.9	13.7	12.5	14.4	13.9	15
5/10	24	50	6.2	10.7	7.9	11.7	9.4	12.6	10.8	13.2	12.1	13.7
	32	40	8.5	13.9	10.9	15.4	13	16.5	15	17.4	16.8	18.1
	30	45	8	13.9	10.2	15.2	12.1	16.2	13.9	17	15.5	17.7
	28	50	7.3	13.7	9.3	14.9	11.1	15.8	12.7	16.6	14.2	17.2
6/12	26	50	6.3	12.6	8.1	13.8	9.6	14.6	11	15.3	12.3	15.8
	24	50	5.4	11.6	6.9	12.6	8.2	13.4	9.4	14	10.5	14.5
	32	40	7.7	14.9	10	16.3	11.8	17.3	13.5	18.1	15.1	18.8
	30	45	7.2	14.8	9.1	16.1	10.9	17	12.4	17.8	13.9	18.4
6/12	28	50	6.5	14.6	8.3	15.8	9.9	16.6	11.3	17.3	12.6	17.9
	26	50	5.5	13.6	7	14.6	8.4	15.4	9.6	16	10.7	16.5
	24	50	4.6	12.5	5.8	13.4	6.9	14.1	7.9	14.6	8.8	15.1

CFL 32

FLOW RATE			2000 m ³ /h		2400 m ³ /h		2800 m ³ /h		3200 m ³ /h		3500 m ³ /h	
PCW	Intake temp. [°C]	rel. hum. [%]	Output [kW]	Discharge temp. [°C]	Output [kW]	Discharge temp. [°C]	Output [kW]	Discharge temp. [°C]	Output [kW]	Discharge temp. [°C]	Output [kW]	Discharge temp. [°C]
4/8	32	40	16.7	14.7	19.1	15.5	21.2	16.2	23.3	16.8	24.7	17.3
	30	45	15.7	14.5	17.8	15.3	19.8	15.9	21.7	16.5	23	16.9
	28	50	14.5	14.2	16.4	14.9	18.3	15.5	20	16	21.2	16.3
	26	50	12.7	13	14.4	13.7	16	14.2	17.5	14.7	18.6	15
5/10	24	50	10.9	12	12.4	12.5	13.8	13	15.1	13.5	16.1	13.7
	32	40	15.2	15.6	17.3	16.4	19.2	17.1	21	17.7	22.3	18.1
	30	45	14.1	15.5	16	16.2	17.8	16.8	19.5	17.3	20.7	17.7
	28	50	12.9	15.2	14.7	15.8	16.3	16.4	17.8	16.9	18.8	17.2
6/12	26	50	11.1	14	12.6	14.6	14	15.1	15.3	15.3	16.3	15.8
	24	50	9.4	12.9	10.6	13.4	11.8	13.8	12.9	14.2	13.7	14.5
	32	40	13.6	16.5	15.5	17.2	17.2	17.9	18.8	18.4	20	18.8
	30	45	12.5	16.3	14.2	17	15.8	17.6	17.2	18.1	18.3	18.4
6/12	28	50	11.4	16.1	12.9	16.7	14.3	17.2	15.6	17.6	16.5	17.9
	26	50	9.6	14.8	10.8	15.4	12	15.8	13.1	16.2	13.9	16.5
	24	50	7.8	13.6	8.8	14.1	9.8	14.5	10.7	14.8	11.3	15.1

COMFORT SLIMLINE VENTILATION UNIT CFL ACCESSORIES



DIRECT EXPANSION COIL EXTENSION MODULE

- Optional, for mounting on the unit, available with connection side on the left or right in the direction of airflow
- Can be combined with CFL-WRG, CFL-EC-ZUL and CFL-EC-ABL
- Cu/Al direct expansion coil removable from the side
- Supply air temperature sensor optionally available (loose)
- Incl. 1 set of mounting brackets [2 pce]
- Filter insertion slot for compact filters with fine dust quality M5 /F7 / F9
- Inspection door allows access to the filter

Size	CFL	10	15
Dimensions [LxWxH]	mm	712 x 508 x 367	712 x 712 x 367
Max. air volume	m ³ /h	1000	1800

CFL 10

FLOW RATE			400 m ³ /h		550 m ³ /h		700 m ³ /h		850 m ³ /h		1000 m ³ /h	
PCW	Intake temp. [°C]	rel. hum. [%]	Output [kW]	Discharge temp. [°C]	Output [kW]	Discharge temp. [°C]	Output [kW]	Discharge temp. [°C]	Output [kW]	Discharge temp. [°C]	Output [kW]	Discharge temp. [°C]
2 °C	32	40	3.4	14.7	4	16.7	4.5	18.2	4.9	19.3	5.2	20.3
	30	45	3.2	14.1	3.8	16	4.3	17.3	4.7	18.4	5	19.3
	28	50	3.1	13.4	3.7	15.1	4.1	16.4	4.5	17.4	4.8	18.2
	26	50	2.7	12.4	3.2	14	3.6	15.2	4	16.1	4.2	16.9
	24	50	2.4	11.4	2.8	12.9	3.2	14	3.5	14.9	3.7	15.5
5 °C	32	40	3	15.9	3.6	17.7	4	19	4.4	20.1	4.7	20.9
	30	45	2.9	15.3	3.4	16.9	3.9	18.2	4.2	19.1	4.5	19.9
	28	50	2.7	14.6	3.3	16.1	3.7	17.3	4	18.2	4.3	18.9
	26	50	2.4	13.7	2.8	15.1	3.2	16.1	3.5	16.9	3.7	17.6
	24	50	2	12.7	2.4	14	2.7	14.9	3	15.7	3.2	16.2
8 °C	32	40	2.6	17.2	3.1	18.8	3.5	20	3.8	20.9	4.1	21.6
	30	45	2.5	16.6	3	18.1	3.3	19.1	3.7	20	3.9	20.7
	28	50	2.3	15.9	2.8	17.3	3.1	18.2	3.4	19	3.7	19.6
	26	50	2	15	2.3	16.2	2.6	17.1	2.9	17.8	3.1	18.3
	24	50	1.6	14.2	1.9	15.2	2.2	16	2.4	16.6	2.5	17.1

CFL 15

FLOW RATE			750 m ³ /h		1000 m ³ /h		1250 m ³ /h		1500 m ³ /h		1800 m ³ /h	
PCW	Intake temp. [°C]	rel. hum. [%]	Output [kW]	Discharge temp. [°C]	Output [kW]	Discharge temp. [°C]	Output [kW]	Discharge temp. [°C]	Output [kW]	Discharge temp. [°C]	Output [kW]	Discharge temp. [°C]
2 °C	32	40	6.4	14.2	7.5	16.1	8.3	17.5	9	18.6	9.7	19.7
	30	45	6.2	13.6	7.2	15.4	8	16.7	8.7	17.7	9.4	18.7
	28	50	5.9	13	6.9	14.6	7.6	15.8	8.3	16.8	8.9	17.8
	26	50	5.2	12	6.1	13.5	6.8	14.7	7.3	15.6	7.9	16.4
	24	50	4.6	11.1	5.3	12.5	5.9	13.5	6.4	14.3	6.9	15.1
5 °C	32	40	5.8	15.4	6.7	17.1	7.5	18.3	8.2	19.3	8.8	20.3
	30	45	5.5	14.8	6.5	16.4	7.2	17.5	7.8	18.5	8.5	19.4
	28	50	5.2	14.2	6.1	15.6	6.8	16.7	7.4	17.6	8	18.4
	26	50	4.5	13.3	5.3	14.6	5.9	15.6	6.4	16.3	6.9	17.1
	24	50	3.9	12.4	4.5	13.5	5	14.4	5.5	15.1	5.9	15.8
8 °C	32	40	5	16.8	5.9	18.2	6.6	19.3	7.1	20.2	7.7	21
	30	45	4.8	16.2	5.6	17.5	6.2	18.5	6.8	19.3	7.3	20.1
	28	50	4.5	15.6	5.2	16.8	5.8	17.7	6.4	18.5	6.9	19.2
	26	50	3.7	14.7	4.4	15.8	4.9	16.6	5.3	17.3	5.8	17.9
	24	50	3.1	13.8	3.6	14.8	4	15.5	4.4	16.1	4.7	16.7

Performance data for refrigerant R407C. Performance data for other refrigerants can be supplied specific to each project.
A max. operating pressure of 28 bar must be observed for R410A.

COMFORT SLIMLINE VENTILATION UNIT CFL

ACCESSORIES



DIRECT EXPANSION COIL EXTENSION MODULE

- Optional, for mounting on the unit, available with connection side on the left or right in the direction of airflow
- Can be combined with CFL-WRG, CFL-EC-ZUL and CFL-EC-ABL
- Cu/Al direct expansion coil removable from the side
- Supply air temperature sensor optionally available (loose)
- Incl. 1 set of mounting brackets (2 pce)
- Filter insertion slot for compact filters with fine dust quality M5 /F7 / F9
- Inspection door allows access to the filter

Size	CFL	22	32
Dimensions (LxWxH)	mm	712 x 915 x 411	813 x 966 x 495
Max. air volume	m ³ /h	2600	3500

CFL 22

FLOW RATE			1000 m ³ /h		1400 m ³ /h		1800 m ³ /h		2200 m ³ /h		2600 m ³ /h	
PCW	Intake temp. [°C]	rel. hum. [%]	Output [kW]	Discharge temp. [°C]	Output [kW]	Discharge temp. [°C]	Output [kW]	Discharge temp. [°C]	Output [kW]	Discharge temp. [°C]	Output [kW]	Discharge temp. [°C]
2 °C	32	40	8.8	13.9	10.6	16.1	12.1	17.6	13.2	18.8	14.2	19.8
	30	45	8.5	13.3	10.2	15.3	11.6	16.8	12.7	17.9	13.7	18.8
	28	50	8.1	12.7	9.8	14.6	11.1	15.9	12.1	17	13	17.8
	26	50	7.1	11.8	8.6	13.5	9.8	14.8	10.7	15.7	11.5	16.5
	24	50	6.3	10.9	7.6	12.4	8.6	13.6	9.4	14.5	10	15.2
5 °C	32	40	7.9	15.2	9.6	17.1	10.9	18.5	12	19.6	12.9	20.5
	30	45	7.6	14.6	9.2	16.4	10.4	17.7	11.5	18.7	12.3	19.5
	28	50	7.2	14	8.7	15.6	9.9	16.8	10.9	17.8	11.7	18.5
	26	50	6.2	13.1	7.5	14.6	8.6	15.7	9.4	16.5	10.1	17.2
	24	50	5.3	12.2	6.4	13.6	7.3	14.6	8	15.3	8.6	15.9
8 °C	32	40	6.8	16.6	8.3	18.3	9.5	19.5	10.4	20.5	11.2	21.2
	30	45	6.5	16	7.9	17.6	9	18.7	9.9	19.6	10.7	20.3
	28	50	6.1	15.4	7.4	16.8	8.4	17.9	9.3	18.7	10	19.3
	26	50	5.1	14.6	6.2	15.8	7.1	16.7	7.8	17.5	8.4	18.1
	24	50	4.2	13.7	5.1	14.8	5.8	15.6	6.4	16.3	6.9	16.8

CFL 32

FLOW RATE			2000 m ³ /h		2400 m ³ /h		2800 m ³ /h		3200 m ³ /h		3500 m ³ /h	
PCW	Intake temp. [°C]	rel. hum. [%]	Output [kW]	Discharge temp. [°C]	Output [kW]	Discharge temp. [°C]	Output [kW]	Discharge temp. [°C]	Output [kW]	Discharge temp. [°C]	Output [kW]	Discharge temp. [°C]
2 °C	32	40	14.6	16.7	16	17.8	17.2	18.7	18.2	19.5	19	20
	30	45	14.1	15.9	15.4	17	16.6	17.9	17.6	18.6	18.3	19.1
	28	50	13.4	15.1	14.7	16.1	15.8	16.9	16.8	17.6	17.4	18
	26	50	11.9	14	13	14.9	14	15.7	14.8	16.3	15.4	16.7
	24	50	10.4	12.9	11.4	13.7	12.2	14.4	13	15	13.5	15.4
5 °C	32	40	13.2	17.7	14.4	18.7	15.5	19.5	16.5	20.2	17.2	20.7
	30	45	12.6	16.9	13.8	17.9	14.9	18.6	15.8	19.3	16.4	19.7
	28	50	11.9	16.1	13.1	17	14.1	17.7	15	18.3	15.6	18.7
	26	50	10.3	15.1	11.3	15.9	12.2	16.5	13	17.1	13.5	17.4
	24	50	8.8	14	9.7	14.7	10.4	15.3	11.1	15.8	11.5	16.1
8 °C	32	40	11.4	18.8	12.5	19.7	13.5	20.4	14.4	21.1	14.9	21.5
	30	45	10.9	18.1	11.9	18.9	12.9	19.6	13.7	20.1	14.2	20.5
	28	50	10.2	17.3	11.2	18	12	18.7	12.8	19.2	13.3	19.5
	26	50	8.6	16.3	9.4	16.9	10.1	17.5	10.8	17.9	11.2	18.2
	24	50	7	15.2	7.7	15.8	8.3	16.3	8.8	16.7	9.2	17

Performance data for refrigerant R407C. Performance data for other refrigerants can be supplied specific to each project.
A max. operating pressure of 28 bar must be observed for R410A.

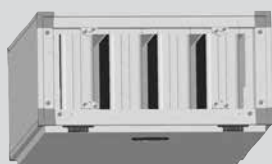

Size	Dimensions (LxWxH)
CFL-10	1017 x 508 x 367
CFL-15	1017 x 712 x 367
CFL-22	1017 x 915 x 411
CFL-32	1017 x 966 x 495

SILENCER EXTENSION MODULE

- Optional, for mounting on the unit
- Mineral fibre splitters in a zinc-plated sheet steel frame, abrasion-resistant surface, non-combustible
- Filter insertion slot for compact filters with fine dust quality M5 /F7 / F9
- Inspection door provides access to the filter; panel below the silencer baffles can be removed for inspection
- Incl. 1 set of mounting brackets (2 pce)

Insertion loss D_e [db(A)]

Frequency	63	125	250	500	1000	2000	4000	8000
CFL 10 Hz	4	11	15	17	25	31	27	21
CFL 15 Hz	4	10	13	15	23	28	24	18
CFL 22 Hz	4	9	11	14	21	26	21	16
CFL 32 Hz	6	10	17	19	22	15	12	9

MIXED AIR / EXHAUST AIR SECTION, SHORT (NOT FOR CFL-32)

- Optional, for mounting on the unit
- Incl. 1 set of mounting brackets (2 pce)
- Intake and discharge position ("E" or "H") and variant (external "A" or internal "I") freely selectable.

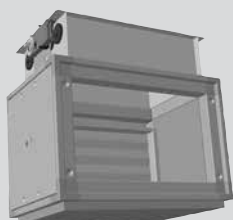

Size	Dimensions (LxWxH)
CFL-10	347 x 508 x 367
CFL-15	347 x 712 x 367
CFL-22	391 x 915 x 411

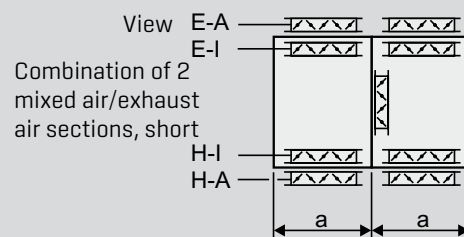

MIXED AIR / EXHAUST AIR SECTION, LONG (NOT FOR CFL-32)

- Optional, for mounting on the unit
- Incl. 1 set of mounting brackets (2 pce)
- Intake and discharge position ("A", "D" or "F") and variant (external "A" or internal "I") freely selectable. Exception: AI and FI, or DI and FI is not possible for space reasons.

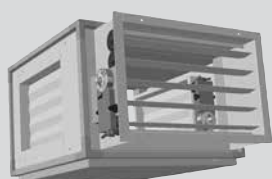

Size	Dimensions (LxWxH)
CFL-10	508 x 508 x 367
CFL-15	712 x 712 x 367
CFL-22	915 x 915 x 411

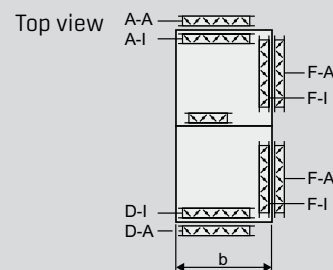

SERVOMOTOR 24 V
VARIABLE SPEED, FOR LOUVER DAMPER AND MIXED AIR MODE

Incl. mounting bracket

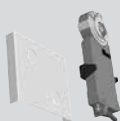

SERVOMOTOR 230 V
FOR LOUVER DAMPER OPEN/CLOSED

Incl. mounting bracket

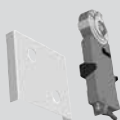

COMFORT SLIMLINE VENTILATION UNIT CFL ACCESSORIES



FLEXIBLE CONNECTION, 4-HOLE PROFILE FRAME

For connection to duct

Size	Dimensions (LxWxH)
CFL-10	130 x 405 x 243
CFL-15	130 x 608 x 243
CFL-22	130 x 811 x 287
CFL-32	130 x 862 x 350

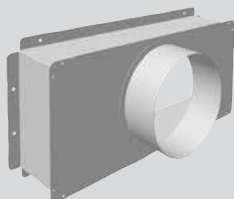

ADAPTOR MODULE

For square to round connection

Size	Length	Connection diameter
CFL-10	130	250
CFL-15	130	250
CFL-22	130	315
CFL-32	300	450

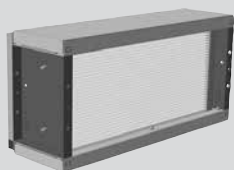

FILTER SECTION WITH INTEGRATED ATTENUATING FUNCTION

- Compact filter available in fine dust quality M5 / F7 / F9 (depth 96 mm).
- Measures for structure-borne sound decoupling already functionally integrated.
- Differential pressure limiter for filter monitoring and indicator manometer are optionally available.

Size	Dimensions (LxWxH)
CFL-10	215 x 409 x 247
CFL-15	215 x 612 x 247
CFL-22	215 x 815 x 291
CFL-32	215 x 866 x 361



HEPA FILTER SECTION WITH INTEGRATED ATTENUATING FUNCTION

- With HEPA-filter H13 in HEPA quality for filtration of particulates such as viruses, bacteria, aerosols etc.
- Measure for structure-borne sound decoupling already functionally integrated.
- Differential pressure limiter for filter monitoring and indicator manometer are optionally available.

Size	Dimensions (LxWxH)
CFL-10	508 x 408 x 250
CFL-15	508 x 612 x 250
CFL-22	508 x 815 x 295
CFL-32	508 x 866 x 359

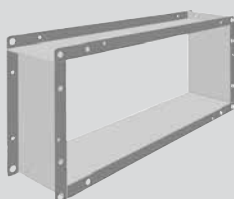

INSULATING FRAME

Size	Dimensions (LxWxH)
CFL-10	70 x 409 x 247
CFL-15	70 x 612 x 247
CFL-22	70 x 815 x 291
CFL-32	70 x 866 x 354

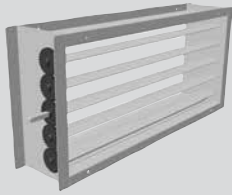

LOUVER DAMPER

For duct, zinc-plated sheet steel
Tightness category 2 to EN 1751

Size	Dimensions (LxWxH)
CFL-10	140 x 409 x 256
CFL-15	140 x 612 x 256
CFL-22	140 x 815 x 306
CFL-32	140 x 866 x 370



SUPPLY / EXTRACT AIR TEMPERATURE SENSOR TUBE, LOOSE

MIXING VALVE FOR PWW HEAT EXCHANGER, LOOSE

Type to match heat exchanger design

DN 10 KVS 0.63
DN 10 KVS 1.0
DN 10 KVS 1.6
DN 15 KVS 2.5
DN 20 KVS 4.0
DN 25 KVS 6.3
DN 25 KVS 10



THREADED CONNECTION SET FOR MIXING VALVES FOR HEAT EXCHANGER

Comprising:

3 union nuts, 3 slot nuts and 3 flat seals



1/2"	DN 10 KVS 0.63
	DN 10 KVS 1.0
	DN 10 KVS 1.6
3/4"	DN 15 KVS 2.5
1"	DN 20 KVS 4.0
1 1/4"	DN 25 KVS 6.3
1 1/2"	DN 25 KVS 10

MIXING VALVE DRIVE, LOOSE

24 V DC; 0-10 V control signal



TRAP WITH NON-RETURN DEVICE

1 1/4", suitable for intake and pressure sides, supplied loose



EXTERNAL, CEILING OR ROOM TEMPERATURE SENSOR

Wall mounted, 2-pole, terminals up to 1.5 mm²

Sensor: NTC5K
Measuring range: -30 °C to +50 °C
IP rating: IP 54
Dimensions: 100 x 60 x 33 mm



OMNIPOLAR ISOLATOR AR6, LOOSE

- lockable, 5.5 kW and 18.5 kW
- on the CFL 15 / 22 in combination with 18.5 kW electric reheating coil extension module
- on the CFL 32 in combination with 18.5 kW electric preheating coil
- on the CFL 10 / 15 / 22 optionally mounted and wired in the control cabinet



COMFORT SLIMLINE VENTILATION UNIT CFL-WRG

ACCESSORIES / CONTROL ACCESSORIES

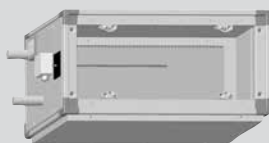

PWW HEATING COIL EXTENSION MODULE

(SEE CFL-EC-ZUL FOR THE PERFORMANCE DATA)

- Optional, for mounting on the unit, available with connection side on the left or right in the direction of airflow
- Fitted as standard with supply air sensor and frost stat
- Incl. 1 set of mounting brackets (2 pce)
- Cu/Al air heater for PWW can be removed from the side
- 1" thread connections
- Bottom panel can be removed for inspection

Size	Output (90/70; t air on=0 °C)	Dimensions (LxWxH)
CFL-10-WRG	15	407 x 508 x 367
CFL-15-WRG	23	407 x 712 x 367
CFL-22-WRG	33	407 x 915 x 411
CFL-32-WRG	48	407 x 966 x 495

COMPACT FILTER M5

Depth 48 mm, fine dust filter



Size	Dimensions (WxH)
CFL-10-WRG	389 x 287
CFL-15-WRG	592 x 287
CFL-22-WRG	795 x 333
CFL-32-WRG	842 x 406

COMPACT FILTER F7

Depth 48 mm, fine dust and pollen filter



Size	Dimensions (WxH)
CFL-10-WRG	389 x 287
CFL-15-WRG	592 x 287
CFL-22-WRG	795 x 333
CFL-32-WRG	842 x 406

COMPACT FILTER F9

Depth 48 mm, fine dust and pollen filter



Size	Dimensions (WxH)
CFL-10-WRG	389 x 287
CFL-15-WRG	592 x 287
CFL-22-WRG	795 x 333
CFL-32-WRG	842 x 406

AIR QUALITY SENSOR

Plug-in design; mixed gas sensor for capturing air quality in offices, hotels, homes, businesses, restaurants etc.



Supply voltage: 24 V AC/DC
Permiss. ambient temperature: 0-50 °C
IP rating: IP 30
Dimensions: 81 x 79 x 26 mm

CO2 SENSOR (ALTERNATIVE TO AIR QUALITY SENSOR)

Plug-in design, for capturing the CO2 content



Supply voltage: 24 V AC/DC
Permiss. ambient temperature: 0-50 °C
IP rating: IP 30
Dimensions: 95 x 97 x 30 mm



DUCT HYGROSTAT

Type KH-10U with wall retainer WH-20, internal setting

Measuring range: 35 to 100 % rel. hum.
IP rating: IP 65
Dimensions: 107 x 70 x 97 mm



ROOM HYGROSTAT

Type RH-2U for wall mounting or on flush box, internal setting

Measuring range: 25 to 95 % rel. hum.
IP rating: IP 30
Dimensions: 95 x 97 x 30 mm

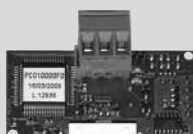

LON INTERFACE FOR WRS-K FOR PLUGGING INTO THE KLM CONTROLLER

For communication between the control unit and the building management system using LON standard network variables, designed as an expansion card, integrated into the DDC control unit. Transceiver FTT-10A / 78 kbit/s. Connection via plug-in/screw terminals. Module is integrated into the existing BMS on site.

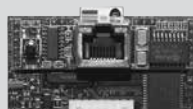

BACNET INTERFACE FOR WRS-K FOR PLUGGING INTO THE KLM CONTROLLER

For communication between the control unit and the building management system, designed as an expansion card, integrated into the DDC control unit. Supported protocols: BACnet Ethernet / BACnet IP. Connection via RJ45 interface. Module is integrated into the existing BMS on site.



ETHERNET INTERFACE FOR WRS-K FOR PLUGGING INTO THE KLM CONTROLLER

For linking the control unit into an Ethernet network (LAN), designed as an expansion card, integrated into the DDC control unit. Supported protocols: HTTP / FTP. Connection via RJ45 interface. Module is integrated into the existing network on site.



MODBUS INTERFACE FOR WRS-K FOR PLUGGING INTO THE KLM CONTROLLER

For communication between the control unit and the building management system, designed as an expansion card, integrated into the DDC control unit. Supported protocols: BACnet Ethernet / BACnet IP. Connection via RJ45 interface. Module is integrated into the existing BMS on site.



KNX INTERFACE FOR WRS-K FOR PLUGGING INTO THE KLM CONTROLLER

For communication between the control unit and the building management system, designed as an expansion card, integrated into the DDC control unit. Connection via screw terminals, 2-pole. Module is integrated into the existing network on site.

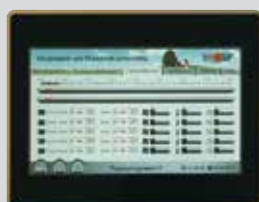

BMK-T10 TOUCH PANEL

Several CFL-WRG units can be operated
For on site installation from the front



BMK-F REMOTE CONTROL

For wall mounting with integral room temperature sensor

6 function keys: On/Off, manual/auto, speed, fresh air, utilisation time extension, intermittent ventilation; LCD screen; fault indication, 24 VA C power supply, RS485 interface (pLAN), IP rating IP 30. Functions: System On/Off, speed setting, specifying fresh air proportion, activating utilisation time extension, activating intermittent ventilation, adjusting set temperature. Dimensions: 135 x 86 x 30 mm

COMFORT SLIMLINE VENTILATION UNIT CFL-WRG ACCESSORIES

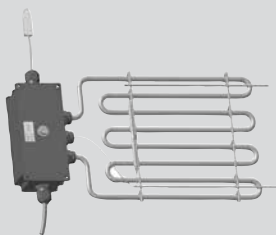

ELECTRIC PREHEATING COIL

- Single stage; can be integrated into the unit as an option, electrical plug-in design
- With integrated manually resettable excess temperature protection (high limit safety cut-out)

Size	Output (kW)	Voltage
CFL-10-WRG	1	230 V / 50 Hz
CFL-15-WRG	2	230 V / 50 Hz
CFL-22-WRG	3	230 V / 50 Hz
CFL-32-WRG	4	230 V / 50 Hz

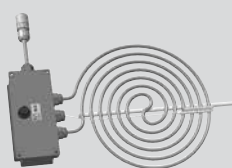

ELECTRIC REHEATING COIL

- Variable control (0-10 V)
- Can be integrated into the unit as an option; electrical plug-in design
- With integrated manually resettable excess temperature protection (high limit safety cut-out)

Size	Output (kW)	Voltage
CFL-10-WRG	1	230 V / 50 Hz

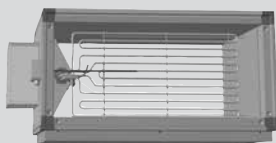

ELECTRIC REHEATING COIL EXTENSION MODULE

- Power cable with 3 x 400 V supply voltage
- Terminal box fitted on the outside of the module
- Optional, for mounting on the unit, available with connection side on the left or right in the direction of airflow
- Fitted as standard with supply air sensor
- Variable control (0-10 V)
- Incl. 1 set of mounting brackets (2 pce)
- Bottom panel can be removed for inspection
- With integrated manually resettable excess temperature protection (high limit safety cut-out)

Size	Output (kW)	Voltage	Dimensions (LxWxH)
CFL-15-WRG	4	400 V / 50 Hz	407 x 712 x 367
CFL-22-WRG	6	400 V / 50 Hz	407 x 915 x 411
CFL-32-WRG	8	400 V / 50 Hz	407 x 966 x 495

AUXILIARY MODULE FOR CONTROLLING SEVERAL FIRE DAMPERS

On request

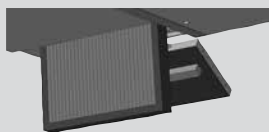

ADDITIONAL INSPECTION DOOR

2 additional doors for simple filter inspection for CFL-WRG 10, 15, 22

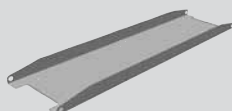

TRANSPORT CARRIAGE CFL-32 WRG

For facilitating handling through low access openings
Mounted on the unit

COMFORT SLIMLINE VENTILATION UNIT CFL-EC

CONTROL ACCESSORIES

CONTROL OF CFL-EC-ZUL OR
CFL-EC-ABL (IN CONJUNCTION WITH COOLING COIL OR DX COIL EXTENSION MODULE)



BML VENTILATION PROGRAMMING UNIT

- Room temperature-dependent control
- Backlit graphic display
- Easy user prompts via plain text display
- Control by rotary selector with pushbutton function
- 4 function keys for frequently used functions
- Installation either in the ventilation module or in the wall mounting base as a remote control
- Only one BML ventilation programming unit required to control up to 7 zones
- Demand-optimised boiler water temperature request via eBus
- eBus interface



WALL MOUNTING BASE FOR BML

Wall mounting base for using the BML ventilation programming unit as a remote control



LM2 VENTILATION MODULE

- LM2 ventilation module for controlling the room temperature via mixer control (PWW or PCW)
- Variable speed motor control in conjunction with EC motor
- Easy controller configuration by selecting predefined system schemes
- Control of a heat generator (PWW) or cold generator
- Demand-optimised boiler water temperature request via eBus
- eBus interface with automatic energy management
- BML ventilation programming unit can be clipped in
- Open / close - louver damper control
- Supply / extract air unit controllable



ISM5 - LON INTERFACE MODULE

Connection of LM2 ventilation module to a building management system using LON standard network variables



CONTROL CABINET

- Room temperature control via mixer control for PWW and PCW
- Control of a heat generator (PWW) and a cold generator

EXTERNAL, CEILING OR ROOM TEMPERATURE SENSOR

COMFORT SLIMLINE VENTILATION UNIT CFL-EC

ACCESSORIES



VARIABLE SPEED CONTROLLER, LOOSE

0-10 V



UNIVERSAL TIMER

For setback mode with 7-day program



COMPACT FILTER M5

Depth 96 mm, fine dust filter

Size	Dimensions (WxH)
CFL-10-EC	389 x 287
CFL-15-EC	592 x 287
CFL-22-EC	795 x 333
CFL-32-EC	842 x 406



COMPACT FILTER F7

Depth 96 mm, fine dust and pollen filter

Size	Dimensions (WxH)
CFL-10-EC	389 x 287
CFL-15-EC	592 x 287
CFL-22-EC	795 x 333
CFL-32-EC	842 x 406



COMPACT FILTER F9

Depth 96 mm, fine dust filter

Size	Dimensions (WxH)
CFL-10-EC	389 x 287
CFL-15-EC	592 x 287
CFL-22-EC	795 x 333
CFL-32-EC	842 x 406

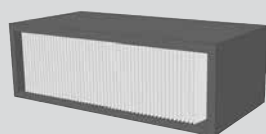

HEPA-FILTER H13

Depth 296 mm, HEPA-filter in HEPA quality

Size	Dimensions (WxH)
CFL-10-EC	393 x 200
CFL-15-EC	597 x 200
CFL-22-EC	800 x 250
CFL-32-EC	851 x 314

INDOOR AIR QUALITY

The room air quality or quality of the indoor air is influenced by the following three factors (see also EN 15251 and EN 13779):

- **Emissions from persons and their activities**
Carbon dioxide emissions from persons' respiration, biological vapours, smoking, personal hygiene products, etc.
- **Emissions from the room**
Vapours from furniture, carpets, paint, adhesives, etc.
- **Outdoor air conditions**
Rural areas, urban areas, dust, fine dust, pollen, etc.

DESIGN CRITERIA

In accordance with EN 15251, various categories are used for indoor air quality and ventilation rate criteria.

DESCRIPTION OF THE APPLICABILITY OF THE VARIOUS CATEGORIES

CATEGORY	DESCRIPTION
1	High level of expectation. Recommended for spaces occupied by very sensitive and fragile persons with special needs, such as disabled or sick persons, very young children and elderly persons.
2	Standard level of expectation. Recommended for new and renovated buildings.
3	Acceptable, moderate level of expectation. Can be applied for existing buildings.
4	Values outside the above categories. This category should only be applied for a limited part of the year.

As the carbon dioxide concentration rises, the ability to concentrate and perform declines, tiredness increases and people feel uncomfortable.

Carbon dioxide is a natural constituent of the earth's atmosphere and is found in outdoor air in concentrations ranging from around 350 ppm (rural areas) to around 500 ppm (urban areas).

COMFORT SLIMLINE VENTILATION UNIT CFL

TECHNICAL INFORMATION

CO₂ LEVEL IN INDOOR ENVIRONMENTS to EN 15251 or EN 13779

The following table from EN 13779 shows the recommended minimum values for the outdoor air flow rate per person. The design air flow rate also takes emissions from other sources into account, such as building materials and furniture.

Category	Unit	Outdoor air flow rate							
		Non-smoking area				Smoking area			
		Standard area		Standard value		Standard area		Standard value	
1	l/s/person m ³ /h/person	> 15	> 54	20	72	> 30	> 108	40	144
2	l/s/person m ³ /h/person	10 - 15	36 - 54	12.5	45	20 - 30	72 - 108	25	90
3	l/s/person m ³ /h/person	6 - 10	21.6 - 36	8	28.8	12 - 30	43.2 - 108	16	57.6
4	l/s/person m ³ /h/person	< 6	< 21.6	5	18	< 12	< 43.2	10	36

MINIMUM AIR VOLUMES PER PERSON

(based on max. CO₂ requirement)

For approx. age	Age-dependent rates		
	Target 1200 ppm	Target 1000 ppm	Target group
0 - 6	19 m ³ /h	25 m ³ /h	Kindergarten
6 - 10	19 m ³ /h	25 m ³ /h	Primary school
10 - 14	23 m ³ /h	30 m ³ /h	Secondary school
14 - 19	24 m ³ /h	33 m ³ /h	Technical college
Adults	28 m ³ /h	37 m ³ /h	

EXAMPLE CALCULATIONS

$$l/s \times 3.6 = m^3/h$$

Example 1:

School, 2 classrooms, each with 30 children aged 14-19 and one teacher.

Required air volume per room, according to max. CO₂ requirement of 1200 ppm

$$\begin{aligned} \text{Calculation: } & 2 \times 30 \text{ persons} \times 24 \text{ m}^3/\text{h} & = & 1440 \text{ m}^3/\text{h} \\ & 2 \times 1 \text{ teacher} \times 28 \text{ m}^3/\text{h} & = & 56 \text{ m}^3/\text{h} \\ \text{Required outdoor air volume: } & & = & 1496 \text{ m}^3/\text{h} \end{aligned}$$

Example 2:

Desired interior category: 1 - smoking area [standard value] 15 persons,

Air volume per room:

$$\begin{aligned} \text{Calculation: } & 15 \text{ persons} \times 40 \text{ l/s} & = & 600 \text{ l/s} \\ \text{Required outdoor air volume: } & & = & 600 \text{ l/s} = 2160 \text{ m}^3/\text{h} \end{aligned}$$

NOTES:

If greater air volumes are required, models from our KG Compact or KG Top range of air handling units can be used.

COMPARISON WITH INTERMITTENT VENTILATION:

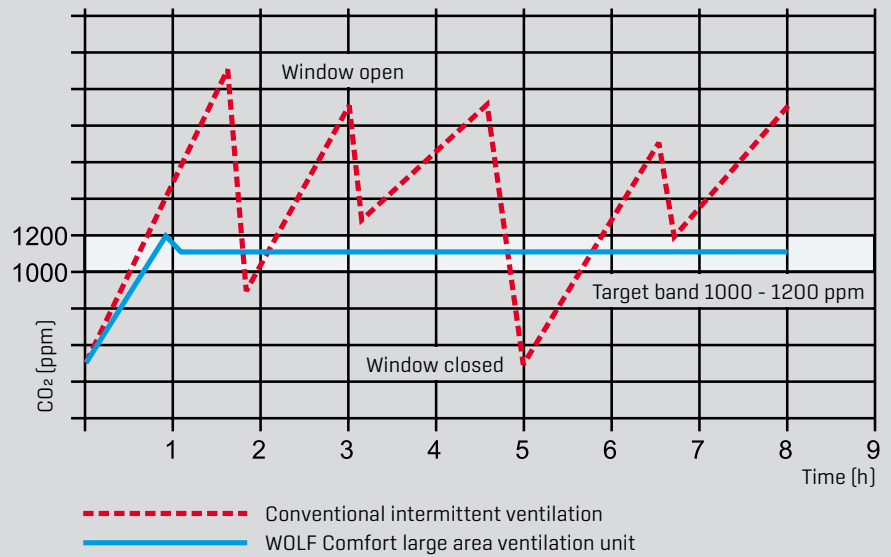

CRITERIA FOR INDOOR NOISE LEVELS to EN 15251 or EN 13779

TYPE OF BUILDING / ROOM	RECOMMENDED SOUND PRESSURE RANGE (DBA)
Open-plan office	35 - 45
Conference room	30 - 40
Classroom, kindergarten	35 - 45
Cafeterias / Restaurants	35 - 50
Shops	35 - 50

MINIMUM CLEARANCE

between outdoor air intake and exhaust air discharge to prevent an air short circuit (EN 13779)

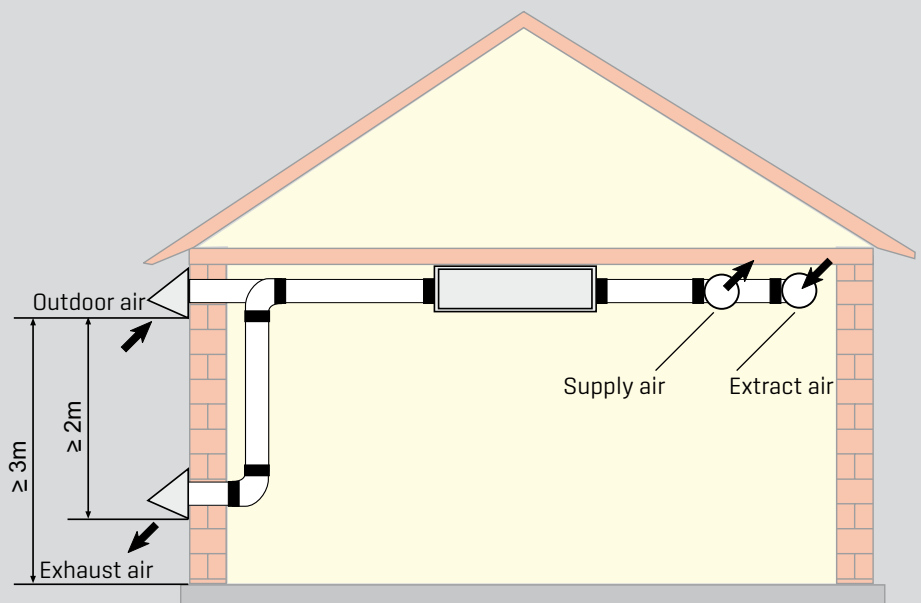

COMFORT SLIMLINE VENTILATION UNIT CFL

TECHNICAL INFORMATION

FUNCTIONAL ILLUSTRATION OF AIR INFLOW:

Dimensions, connecting frame:

Size	CFL	10	15	22	32
Height	H1 mm	247	247	291	354
Width	B1 mm	409	612	815	866
Height	H2 mm	311	311	355	418
Width	B2 mm	473	676	879	930

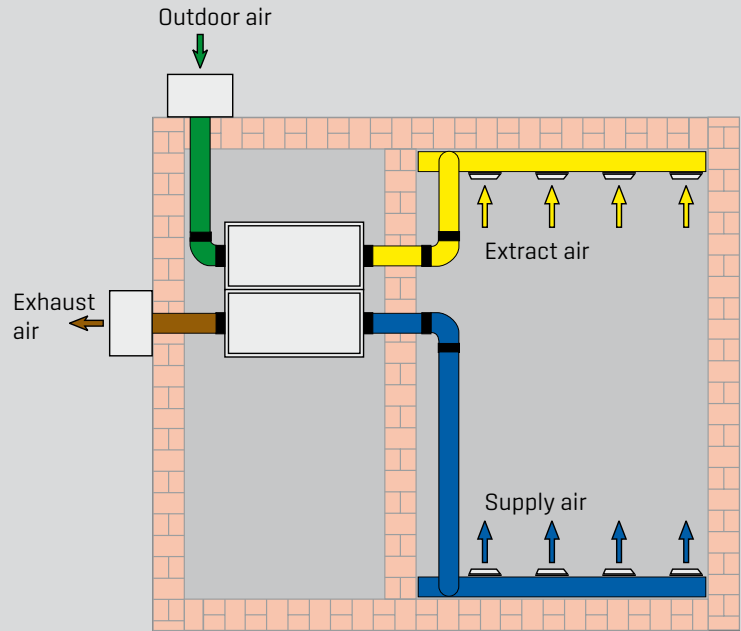
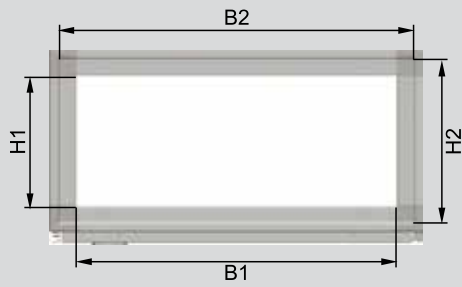

Figure: Top view CFL-WRG

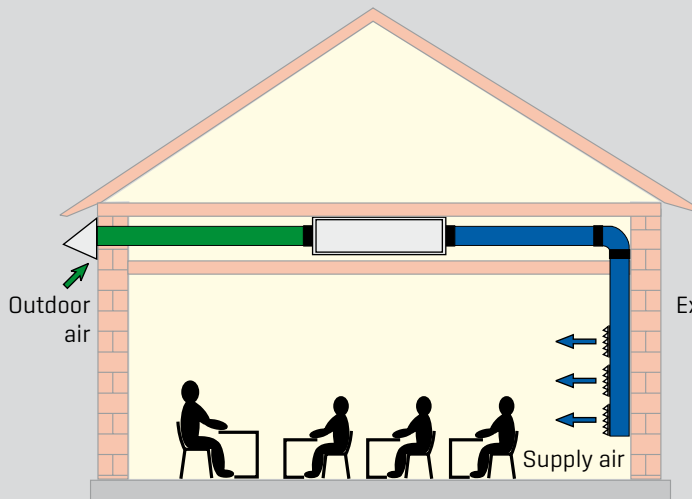

Figure: Side view CFL-EC-ZUL

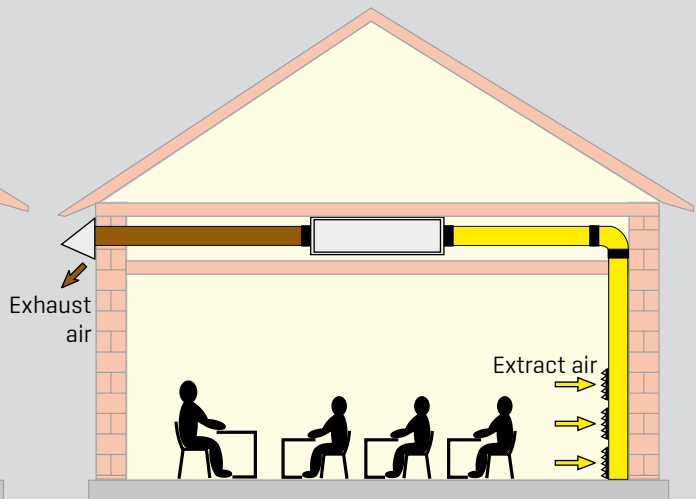
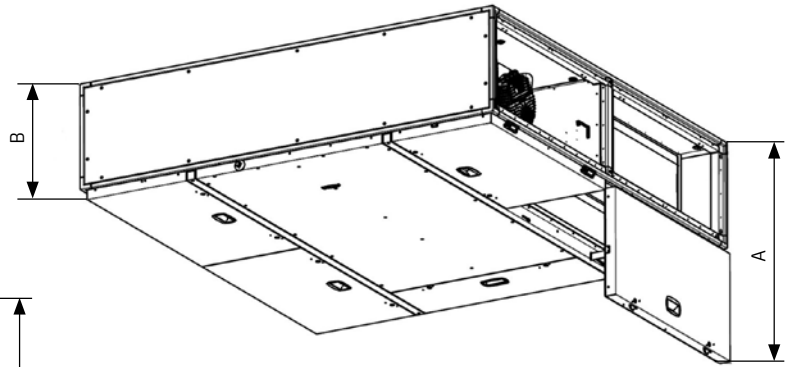
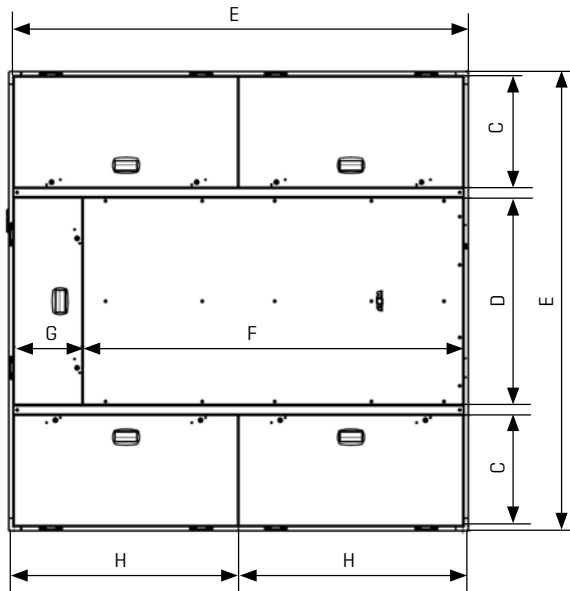

Figure: Side view CFL-EC-ABL

COMFORT SLIMLINE VENTILATION UNIT CFL
TECHNICAL INFORMATION

INSPECTION DOOR SWING RANGE, CFL-WRG SLIMLINE VENTILATION UNIT (CFL 32)



	A	B	C	D	E	F	G	H
CFL-32	950	495	464	870	1932	1598	286	942

INSPECTION DOOR SWING RANGE, CFL-WRG COMFORT SLIMLINE VENTILATION UNIT (CFL 10 / 15 / 22)

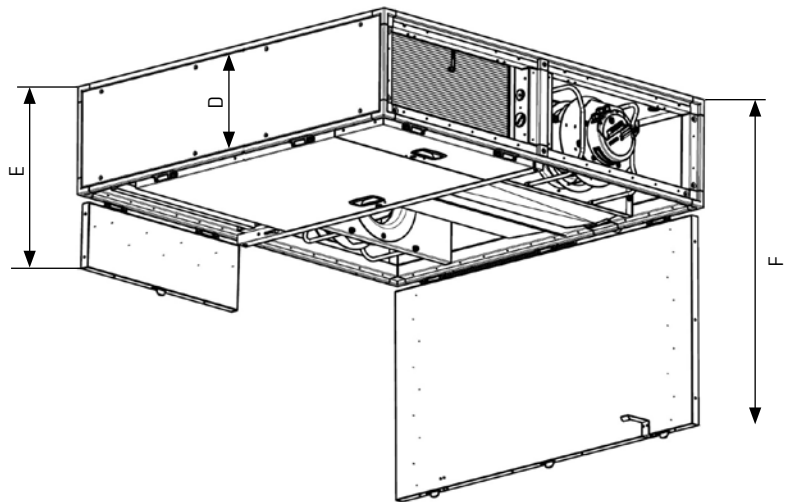
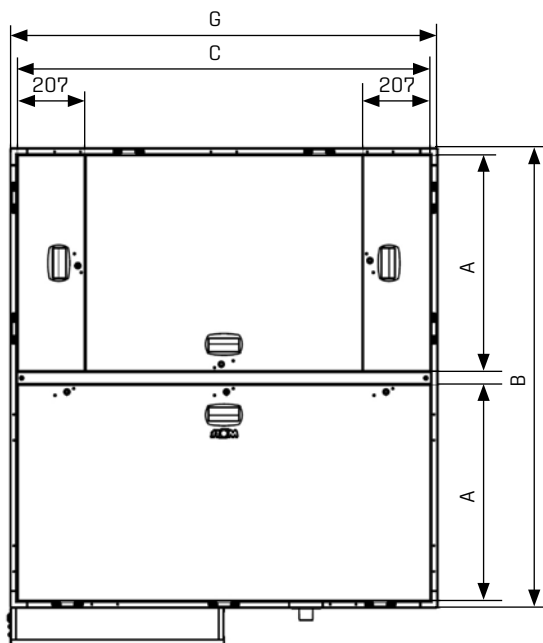

	A	B	C	D	E	F	G
CFL-10	464	1017	1278	367	579	836	1322
CFL-15	668	1423	1278	367	579	1040	1322
CFL-22	871	1830	1481	411	623	1287	1525

Dealer address

WOLF GMBH / P.O. BOX 1380 / D-84048 MAINBURG / TEL. +49.0.875174-0 / FAX +49.0.875174-1600 / www.WOLF.eu

